



De Nora Water Technologies Introduction

Presenter name

De Nora Water Technologies



Agenda

Introduction to De Nora Water Technologies (DNWT)

Markets and applications

- ④ Municipal water and wastewater
- ④ Power
- ④ Marine

Product introductions

- ④ Gas feed disinfection
- ④ Chlorine dioxide generators
- ④ Electrochlorination
- ④ Potable water filter floors
- ④ Tertiary and biological wastewater filters
- ④ Membrane filtration

Detailed product overviews

De Nora 2014 Facts & figures

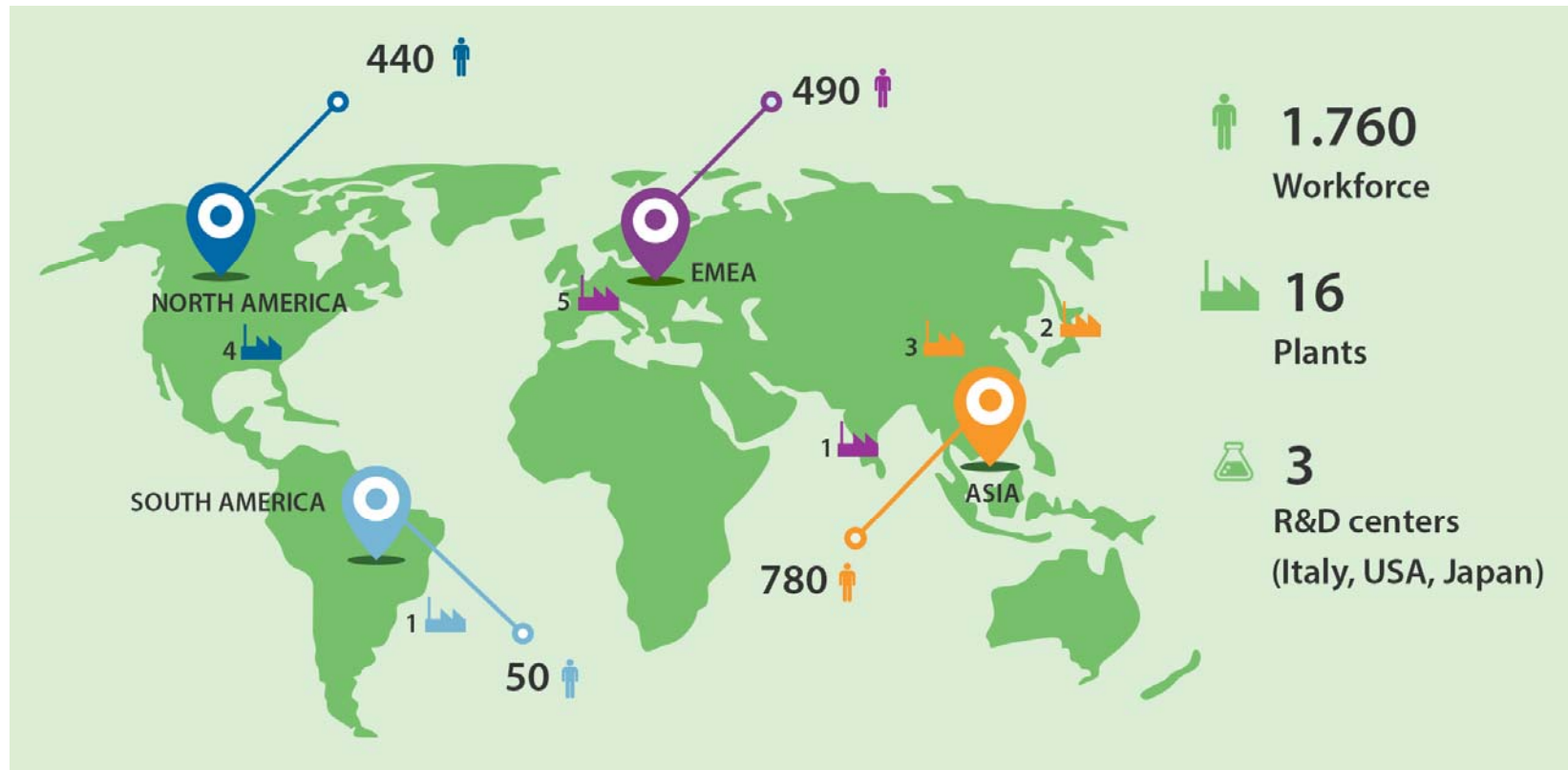

With 2014 global close to €0.5 billion , De Nora is a leading designer, manufacturer and supplier of electrolyzers, electrodes, coatings and technologies to serve electrochemical processes in diversified markets.

De Nora Vision



Strategy and Core Values

- ④ Leadership in electrochemistry through excellence in R&D
- ④ Worldwide presence
- ④ Outstanding engineering and manufacturing capability
- ④ Business partnership used as springboard for growth
- ④ Motivated, dynamic and talented people

“Deliver innovative technologies, products and services to win future challenges coming from environmental and industrial needs”

De Nora strategic pillars



ONE COMPANY providing a comprehensive portfolio of performing products services and applications.

De Nora Business Structure

Three De Nora business groups ensure our organisation is aligned to the needs of our key customer segments.



Electrode Technologies

Legacy business and traditional activities:

- Ⓝ Chloralkali
- Ⓝ Surface finishing
- Ⓝ Electronics
- Ⓝ Mining
- Ⓝ Cathodic protection
- Ⓝ Pools
- Ⓝ Energy storage

ELECTRODES & SERVICES

Water Technologies

Products and applications related to water and wastewater treatment:

- Ⓝ Energy
- Ⓝ Marine
- Ⓝ Municipal
- Ⓝ Industrial water and wastewater

TECHNOLOGY & SERVICES

Next

Products and applications related to disinfection and healthcare:

- Ⓝ Agriculture and livestock
- Ⓝ Food processing
- Ⓝ Professional cleaning
- Ⓝ Veterinary and animal care

SYSTEMS & ELECTRODES

A new face for a global leader

In July 2015, De Nora acquired
The Severn Trent Water Purification
Technologies division



Customer benefits

Long term partnership since 2002

- ④ Continuity for our customers

De Nora reputation for quality, performance & innovation

- ④ Continued reliable and high quality solutions

Long history of project delivery and a global operational setup

- ④ Strong and stable partner with a truly global support

Research & development focus

- ④ More product developments, even greater operating advantages, a full range of disinfection technologies including ozone disinfection

De Nora Water Technologies

De Nora Water Technologies, previously Severn Trent Services Water Purification, is a leader in the field of water and wastewater treatment. We offer the most reliable, effective and trusted brands that we have developed over the course of 50 years' experience across municipal water, energy and marine applications.

Our global support network and skilled staff provide the highest level of support to our customers.

Municipal Water & Wastewater

De Nora Water Technologies provides a comprehensive range of solutions for the treatment of potable water, tertiary and biological wastewater.

We have more than 50 years experience in providing effective, safe and efficient technologies to ensure our municipal customers exceed their treatment obligations.

Our award winning technologies include TETRA® filtration and Capital Controls® disinfection solutions.



Municipal Water & Wastewater - Solutions

TETRA® Filters

- Ⓝ Nitrification
- Ⓝ Denitrification
- Ⓝ Tertiary solids removal
- Ⓝ Potable water filtration
- Ⓝ Desalination pre-treatment



Water & wastewater disinfection

- Ⓝ Capital Controls® Gas Feed disinfection
- Ⓝ Residual analysers, controllers and gas detectors
- Ⓝ ClorTec® brine electrochlorination
- Ⓝ EST™ scrubbers

UAT™ Membrane Filtration

- Ⓝ Desalination

Bayoxide® E33 / SORB®

- Ⓝ Inorganic removal

Municipal Water & Wastewater - Experience

A world leader in gas feed disinfection

>65% of the world's municipal (brine) electrochlorination installation base

Installed the biggest municipal electrochlorination system in the world

40% of the reuse capacity in Florida uses TETRA filters

>400 TETRA biological and tertiary wastewater filters worldwide

The biggest deep bed denitrification filter is a TETRA Denite in the USA

LP Block DPL filter floors used at the biggest desalination plants in the world



MARINE

From ballast water management solutions through to marine sewage treatment systems and water makers, De Nora Water Technologies has it covered.

Our solutions for marine applications have the highest quality certifications and deliver exceptional levels of reliability to ensure operators minimise down time and avoid potential issues while in remote locations.



Marine - Solutions

BALPURE®

- 🌱 Ballast Water Management

MARINER OMNIMPURE® and OMNIPURE™

- 🌱 Marine sewage treatment

UAT™

- 🌱 Water makers



MARINE - EXPERIENCE

DNWT has been active in the Marine sector since the advent of the OMNIPURE sewage treatment units.

Small, automated treatment systems for the small vessel market

The industry's first 'wall mount' sewage treatment unit, the Mariner Series 55.

Expansion has occurred in the live-aboard and fisheries marine sector.



Energy

Our solutions for oil, gas and power generation are delivered through our De Nora Water Technologies (DNWT).

DNWT offshore marine sanitation systems and seawater electrochlorination solutions are specifically designed to operate for long periods in hazardous environments with minimal maintenance requirements.

That's why they are the preferred solution for the energy sector.



Energy - Applications

OMNIPURE™ Sewage treatment

- Ⓝ Offshore marine sanitation

SANILEC® and SEACLOR®

Seawater electrochlorination

- Ⓝ Cooling water disinfection
- Ⓝ Desalination water disinfection

UAT Membrane Filtration

- Ⓝ Offshore water makers

EST Scrubbers

- Ⓝ Exhaust gas scrubbers



Energy - Experience

>2000 installations of OMNIPURE marine sewage systems globally

UAT Membrane filtration systems are packaged specifically for the offshore oil/gas sector with reliability and robustness in mind.

De Nora is a preferred solutions provider of electrolytic technology for the offshore oil and gas market



Aftermarket Solutions

DNWT Aftermarket Offering:

- ④ Trained and knowledgeable staff understand how to maximize product life and efficiency
- ④ Spare parts availability across all De Nora lines
- ④ Warranty and service plans available
- ④ 24/7 technical support





Product Overviews

Introductions

De Nora Water Technologies

Filtration Products



TETRA® Denite®
Denitrification System



TETRA® LP Block
Underdrain Filter
Systems



TETRA® DeepBed™
Tertiary/AWT Filtration



SORB 33® / Bayoxide® E33
Arsenic Removal



UAT™
Membrane/Desalination Systems



TETRA® SAF
Biological Reactor

TETRA[®] DeepBed Filters - Tertiary Wastewater Filters

Introduction

De Nora Water Technologies

The TETRA Advantage

1. Proven technologies
2. Process expertise and excellence
3. Efficient treatment
4. Robust and reliable solutions
5. Global installation base
6. Strong and trusted brand
7. Aftermarket support packages



TETRA Process Technologies

DeepBed™ Filters

- ④ Coarse monomedia
- ④ SNAP-T Block underdrain
- ④ Stainless steel air headers

Bioreactors

- ④ SAF (BOD Removal Nitrification)
- ④ Denite® (Denitrification)
- ④ CoLOX™ (BOD Removal, Nitrification)
- ④ SDF™/SAF/Denite Patented (Predenitrification/Nitrification/denite)



TETRA DeepBed Filter Origin

Used in steel mills in Germany after WWII, Pintsch Bamag 1950s development, 3D vs 2D filtration

Applied to tertiary filtration of municipal wastewater after 1960 – Dravo Corp

Biological applications (Denite) developed in the 1970s – Dravo Corp

Proprietary features developed – TETRA Technologies, Inc 1980s to 2000s

Pintsch-Bamag → Dravo Corp → TETRA → STS → DNWT

TETRA name recognition / registration ®

Robust – suitable for heavy-duty applications

DeepBed Tertiary Filtration

Nozzle-less

- Ⓝ Non-clogging

Low backwash volumes

- Ⓝ 2 to 4% of forward flow

Virtually no media loss

Low backwash water rates

- Ⓝ 6 gpm/ft²

No need to chlorinate

Low maintenance

- Ⓝ Some facilities 25+ years



Profile Of Filter Components

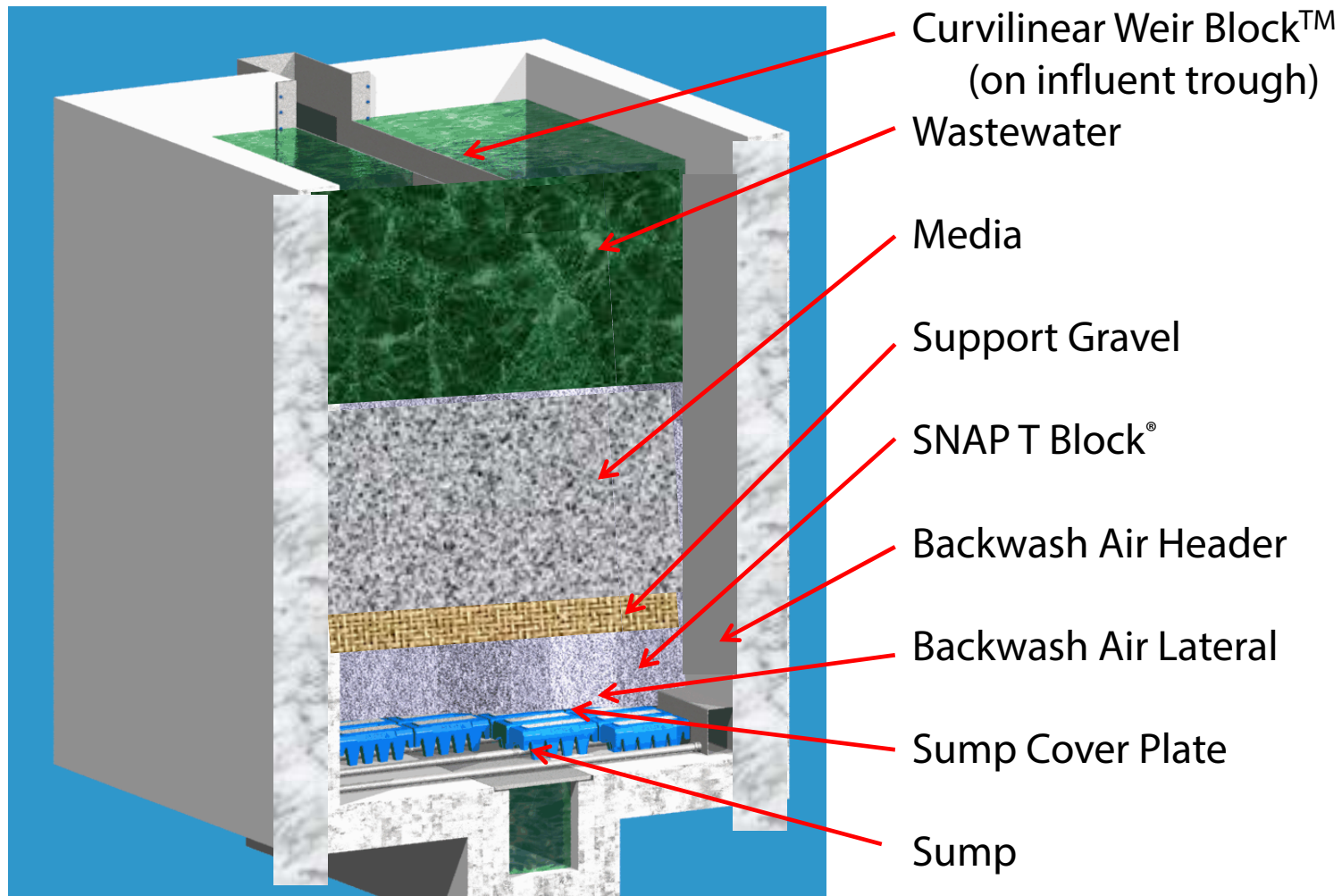

DeepBed Filter Key Component No. 1

SNAP T[®] BLOCK

- ④ Specifically designed for wastewater applications
- ④ HDPE jacket
- ④ 5000 psi concrete filled
- ④ Non-buoyant (unlike DPL)
- ④ Large side and upward passages
- ④ Laid without grout on filter floor
- ④ 4% filter area
- ④ Provide superior distribution of air and water, separately or concurrently
- ④ Easy assembly
- ④ Maintenance-free
- ④ Low head loss



DeepBed Filter Key Component No. 2



MEDIA

- ④ 4 to 6 feet bed depth
- ④ 2+ pounds / sq ft per BW of solids capture
- ④ Effective size of 2.0 – 3.0 mm
- ④ Maximum Uniformity Coefficient of 1.40
- ④ Minimum sphericity of 0.80
- ④ Minimum Hardness of 6.0 on Moh Scale

DeepBed Filter Key Component No. 3

AIR DISTRIBUTION SYSTEM

🌱 Zero maldistribution

Separate from underdrain

Box Header, 304 SS

Air Laterals, 304 SS

Sump Covers

Wye-Wall Construction

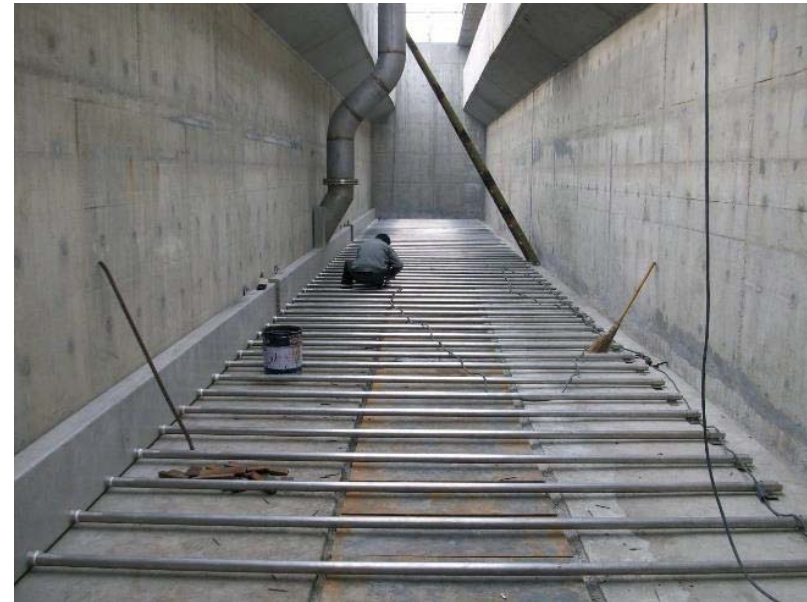

TETRA® SNAP T® Block Principles of Operation

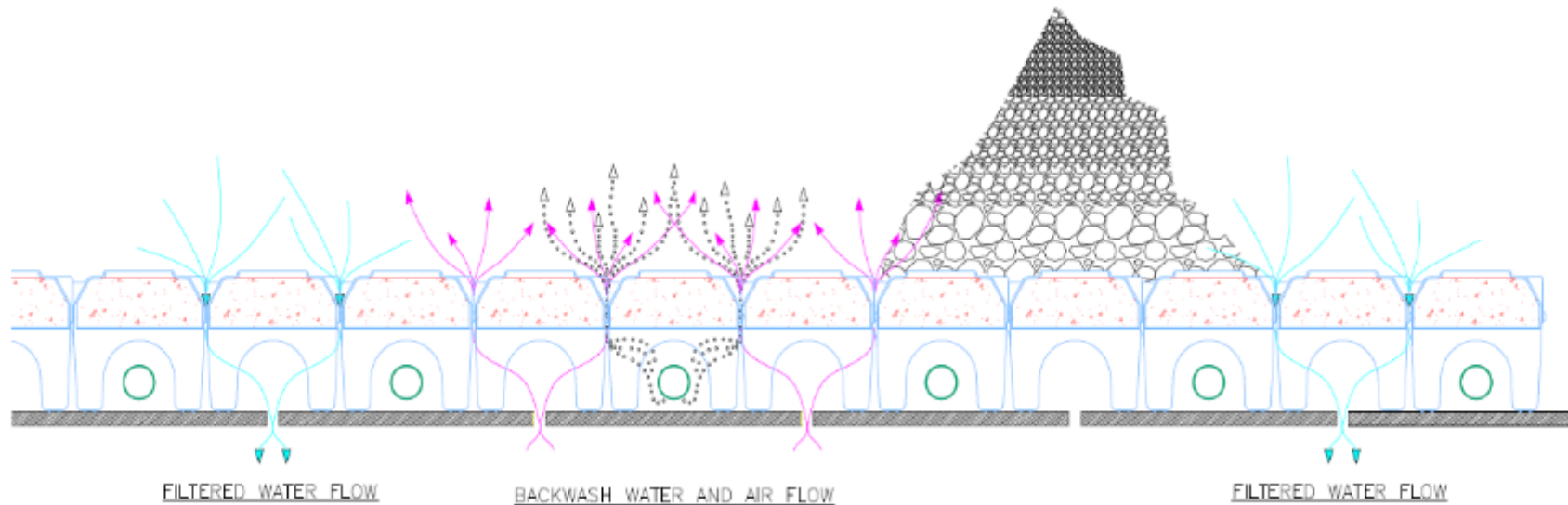
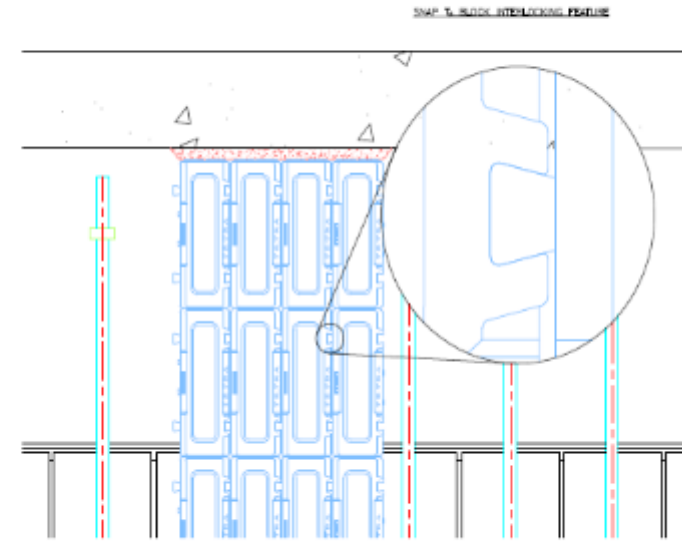
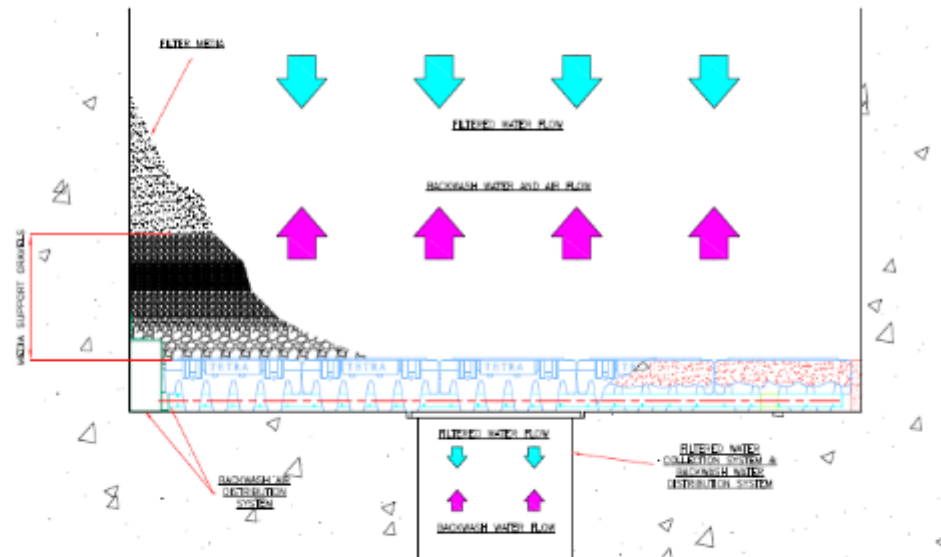

Operation - Filtration



Operation - Backwash



DNWT Experience

Over 650 DeepBed Filter installations for wastewater

The biggest deep bed denitrification filter is a TETRA Denite and will soon be replaced by another DNWT installation at Back River

Brought Air & Water Backwashing to USA 50 Years Ago

Approximately 400 Installations

Nearly 350 MGD of Reuse Quality Effluent in Florida

Industry Pioneer on DeepBed Filters & Bioreactors

Holder of Numerous Trade Secrets & a Patent Estate

🌱 14 Patents & 5 Patents Pending

Overview Of TETRA Biological Filters

Biofilters are variants of basic TETRA DeepBed Filter

- ⊘ Media size and depth
- ⊘ Aeration, no aeration, intermittent aeration
- ⊘ Upflow vs. downflow
- ⊘ Backwash requirements
- ⊘ Bumping requirements
 - Water Bump
 - Air bump

Dual parallel ~~lateral~~ underdrains

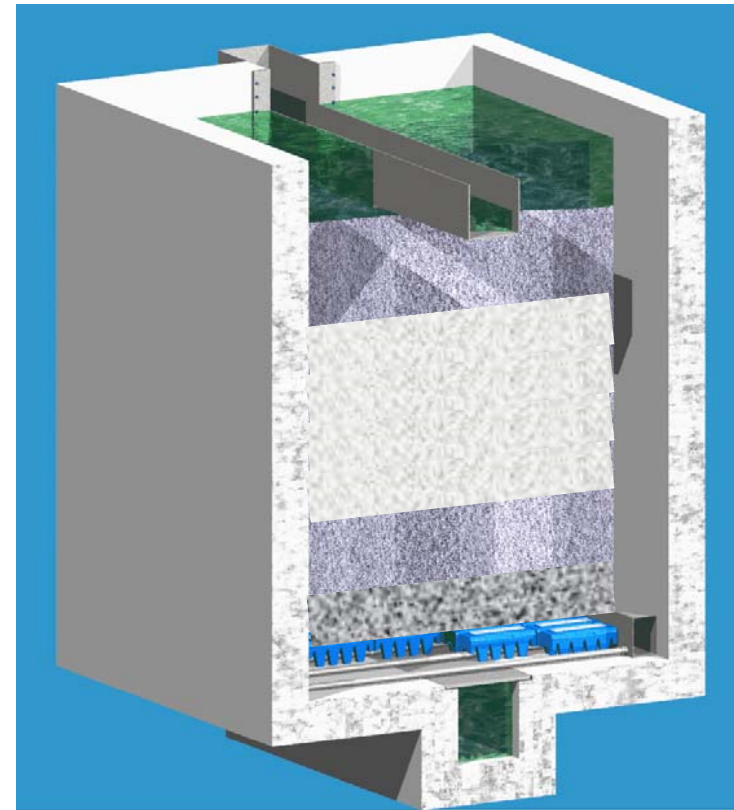

Denite Denitrification And SS Filtration

Advanced wastewater treatment
(AWT)

Combined nitrate and Suspended
solids removal

Denitrifying bacteria on media
reduce NO_3 to N_2 gas.

Methanol – BOD acts as a food
source for the bacteria

Easy conversion of DBF into
Denite by adding methanol to
feed water.



Howard J. Curran WWTP
Tampa, FL
Denite Filters with 100 MGD capacity

CoOX Reactor

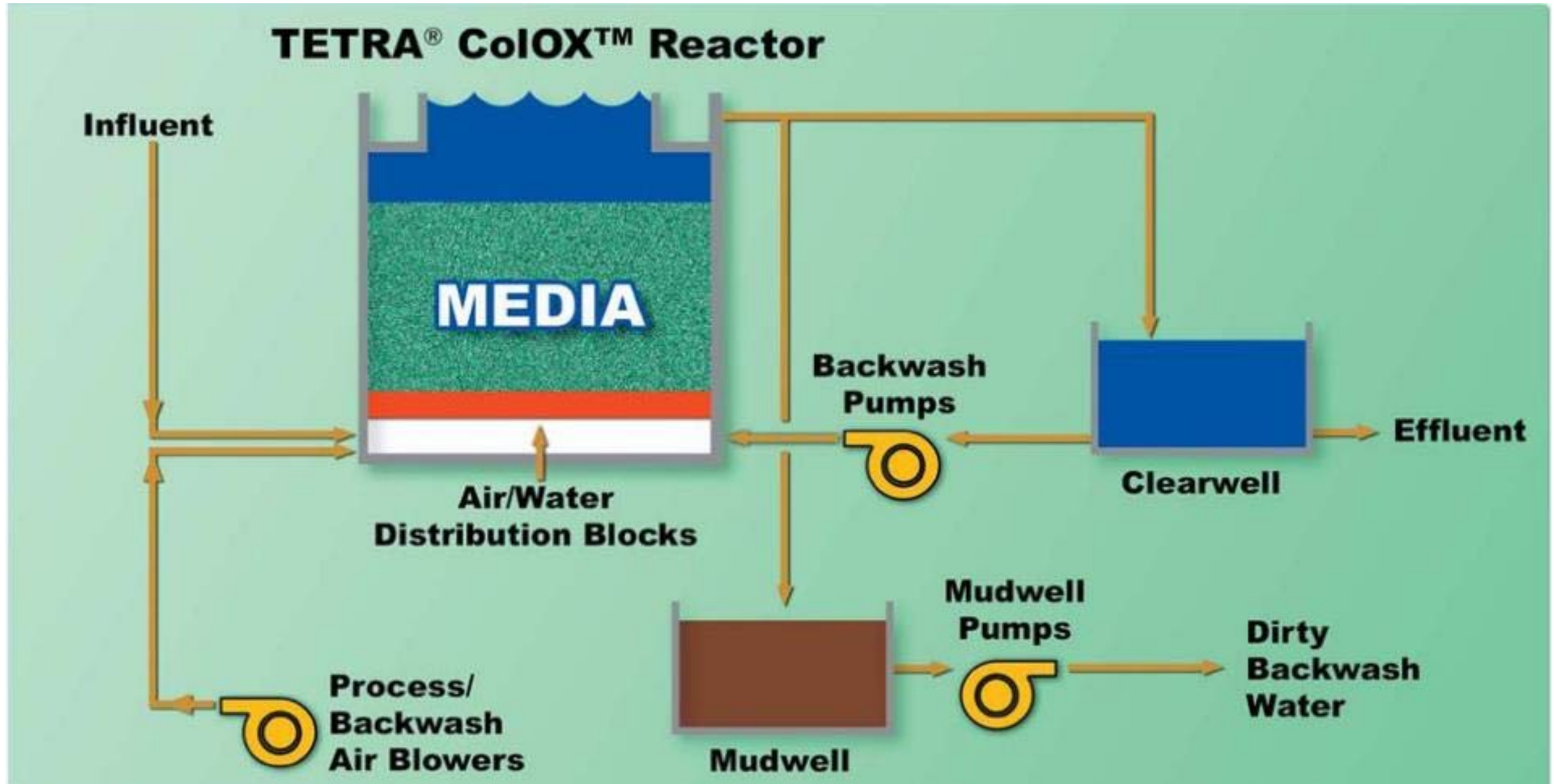

CoIOX

Space saving aerobic bioreactor

Nitrifies ammonia nitrogen ($\text{NH}_3\text{-N}$) to nitrate (NO_3^-)

Superior BOD removal.

Suspended solids removal eliminating secondary clarification



Koppers Coke Plant
Wastewater CoIOX System

SAF – Submerged Aerated Filter

Submerged aerated filter for BOD and ammonia removal

Upflow space saving aerobic bioreactor

Unit does not require backwashing

Often used in combination with DeepBed filter to obtain reuse quality effluent



TETRA SAF

Does NOT Require Backwashing

Applied loadings @20 C for 85-95% removals

- ⊕ BOD: 0.8 -1.5 kg BOD/m³/d
(50-94 lb/kcf/d)
- ⊕ Nitrification: 0.2-0.9 kg N/m³/d
(12-56 lb/kcf/d)

Hydraulic loadings of 2-12 m/h
(0.8-5.0 gpm/sf)

Nitrification

Large media – ES 28-40 mm (3/4" x 1 1/2" gravel or BF slag)

10' - 26' (3m – 8m) media depth



Industrial Wastewater

Industries Served

Iron & Steel

Pulp & Paper

Refining

Oil & Gas

Power

Products

DeepBed Gravity filter

DeepBed Pressure filters

Bio-Filters CoLOX

Engineering Services

Industrial Wastewater - PDBF



DNWT TETRA Project No. 22365
Client: Nustrip

Industrial Wastewater - PDBF



DNWT TETRA Project No. 22571
Client: Nucor Steel
Location: Cofield, NC

Industrial Wastewater - PDBF

Vertical Pressure Vessels:

- ⊕ Standard Diameters:
 - 8'-0" (2.44 m) diameter
 - 11'-0" (3.35 m) diameter
 - 12'-6" (3.81 m) diameter
 - 14'-0" (4.27 m) diameter
 - 10'-0" (3.00 m) diameter
 - 12'-0" (3.66 m) diameter
 - 13'-0" (3.96 m) diameter
 - 16'-6" (5.03 m) diameter
- ⊕ Media Depth: 4 – 6 feet typical (1.22 m – 1.83 m)

Horizontal Pressure Vessels:

- ⊕ Mainly for High Flow Applications
 - ~10,000 GPM (~54,500 m³/d)
- ⊕ Standard Diameter is 14'-0" (4.27 m)
- ⊕ Max. Length = 36'-0" (10.98 m) -Overall 40'-0" (12.20 m)
- ⊕ Media Depth: 4 feet (1.22 m)

85% of steel mills in USA use TETRA filters



TETRA[®] LP Blocks - Dual Parallel Lateral Filter Underdrains

De Nora Water Technologies

U & LP Block™ Underdrains Dual Parallel Lateral (DPL)



TETRA Potable Water Filter Structure

Potable Water Filter

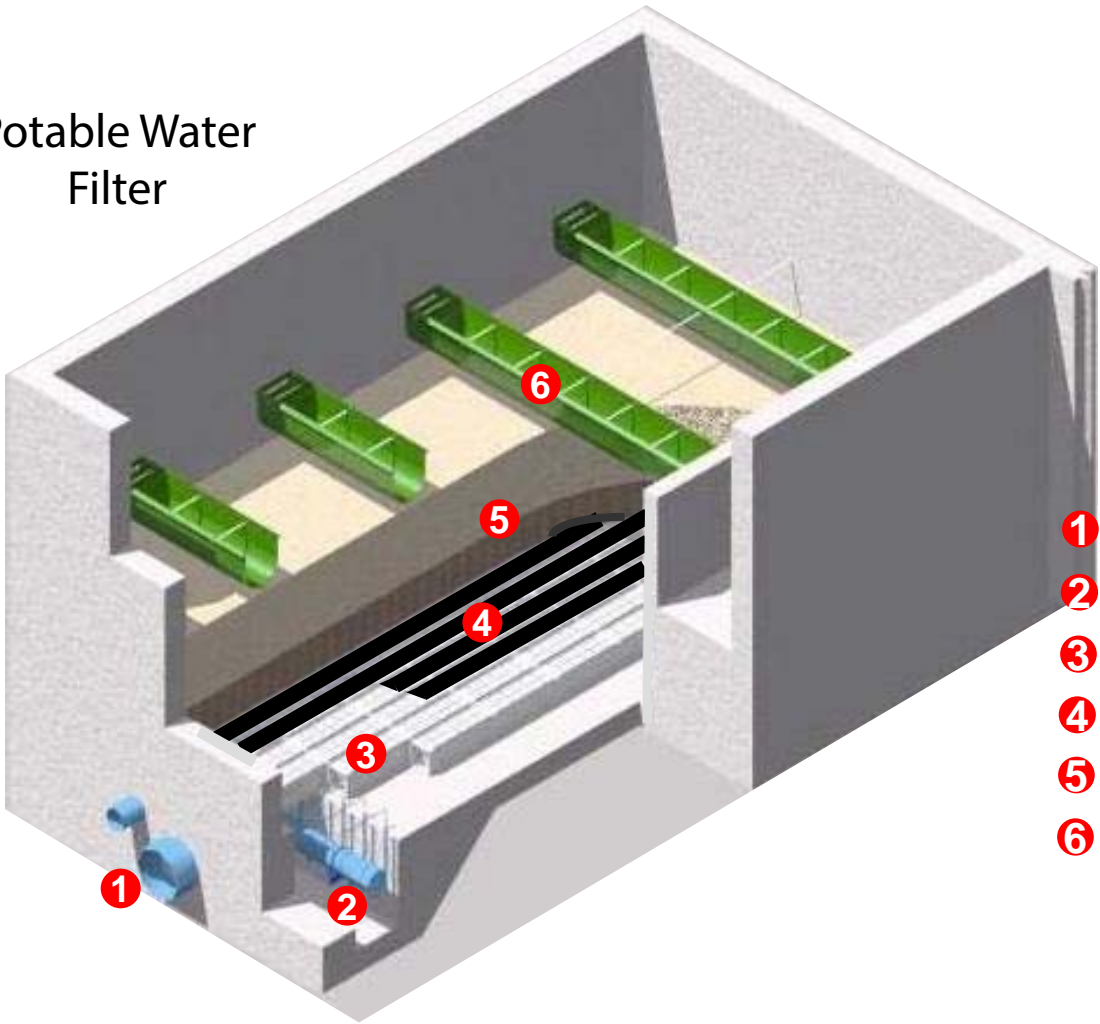

- ① Clean Effluent/Backwash Inlet
- ② Backwash Air Header
- ③ TETRA "U" or "LP" Block™
- ④ TETRA Media Retention Plate
- ⑤ Dual Filter Media - Coal & Sand
- ⑥ Inlet Water Distribution Troughs

TETRA LP Block - Features & Benefits

No moving parts or nozzles

- ⌘ Easy maintenance and long life

Lower profile

- ⌘ Greater media depth possible
- ⌘ More height for air/water BW

Wider profile

- ⌘ Fewer blocks and joints, less grout and shorter installation time

Even distribution of air/water backwash

- ⌘ Efficient bed cleaning
- ⌘ Longer Run Times
- ⌘ Reduced operating costs



Underdrains - U Block™

1996 First Installation

No Moving or Wearing Parts

Low Head Loss & Non Clogging

Even Air & Water Distribution

Maintenance Free Life (15 – 20 years)

+/- 5% Maldistribution up to 60' (18.3 M)
laterals

Snap Fit for Easy Assembly

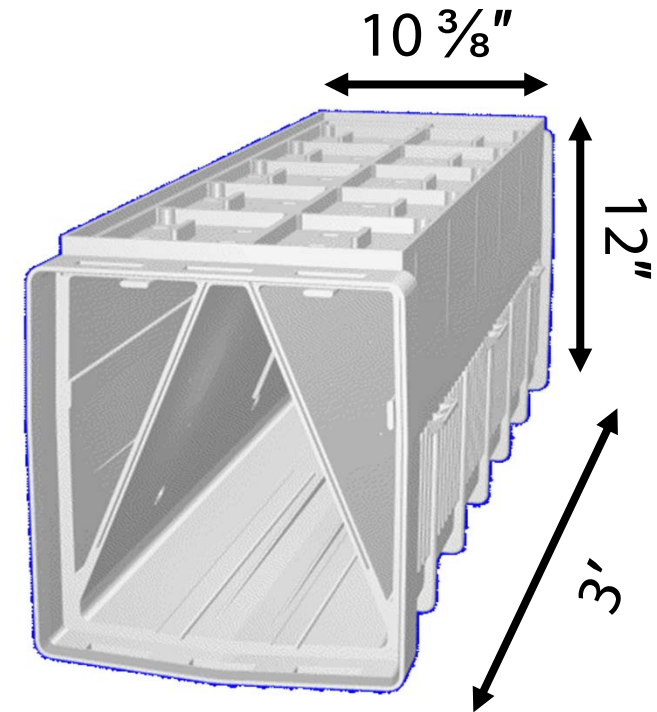

Underdrains - LP Block

1999 First Installation

Lower – Wider Profile

10% Additional Active Area

1/3 fewer blocks to cover floor

Fewer Joints = Less Grout

Grout Grip™ prevents blowout

+/- 5% maldistribution up to 33' (10 M)

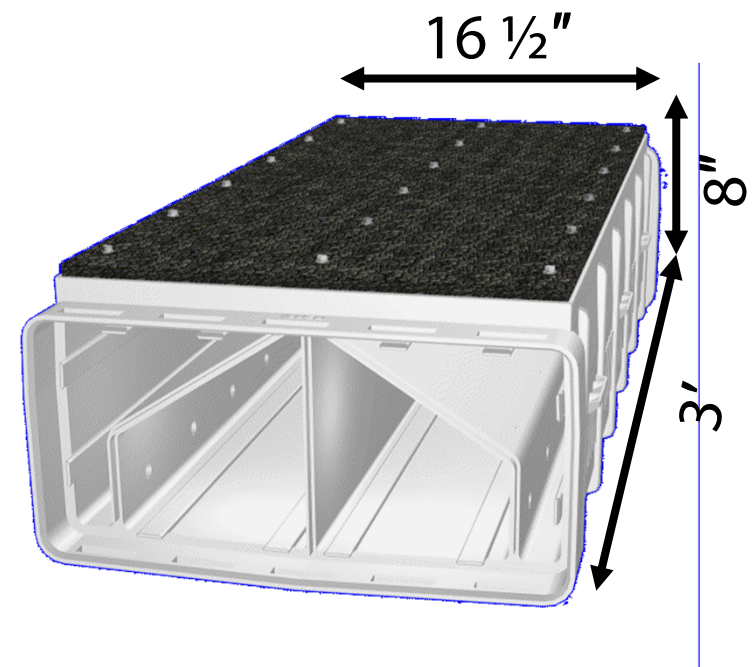

Primary & Secondary Laterals

Secondary Laterals

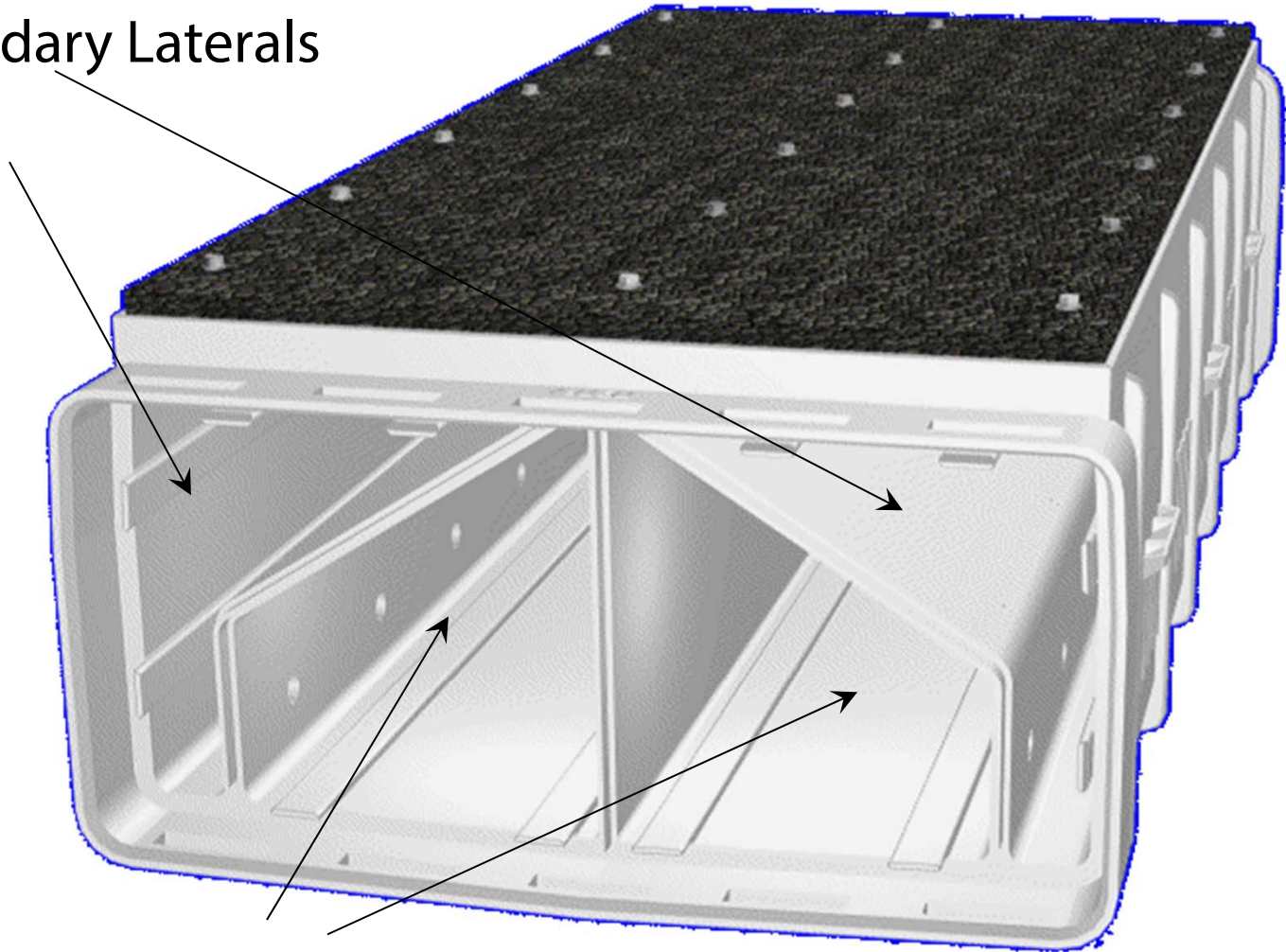

Primary Laterals

Single Lateral Distribution

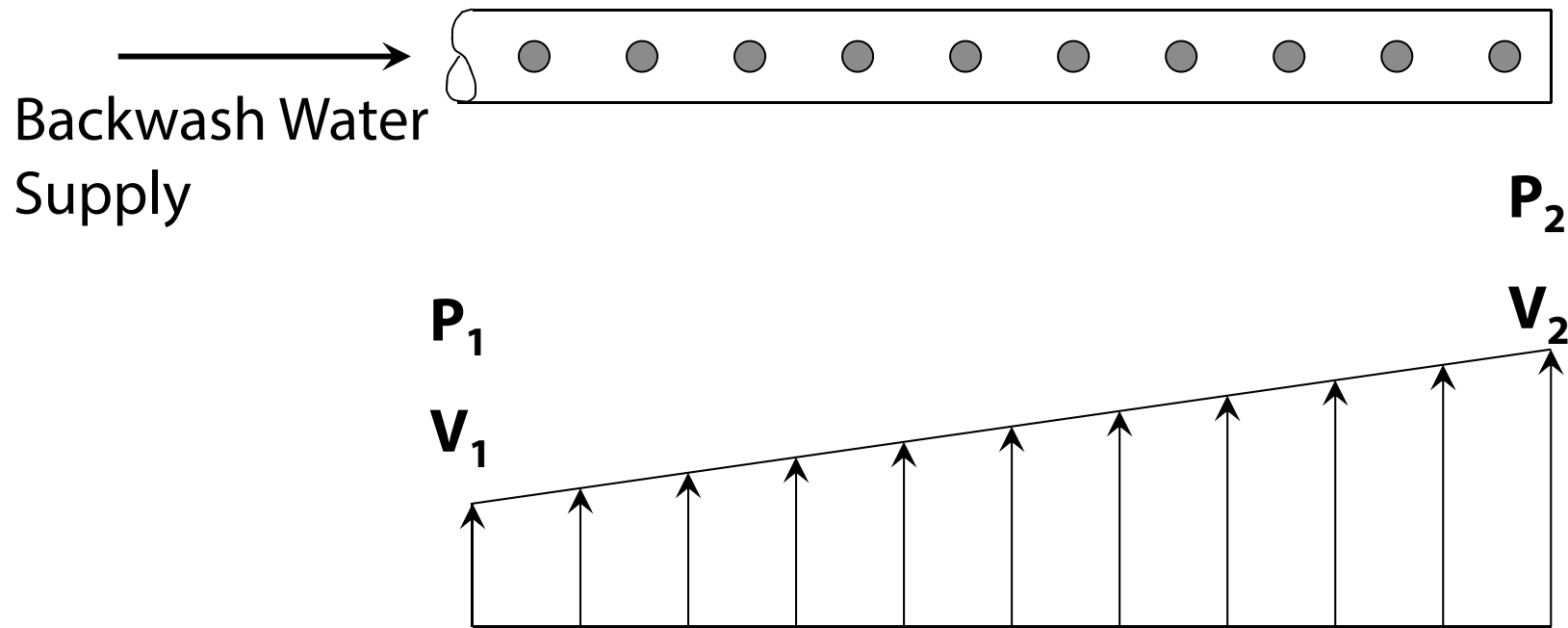

Bernoulli's Equation:

$$P_2 - P_1 = V_1^2 / (2g) = \text{Velocity Head}$$

Dual Parallel Lateral Theory

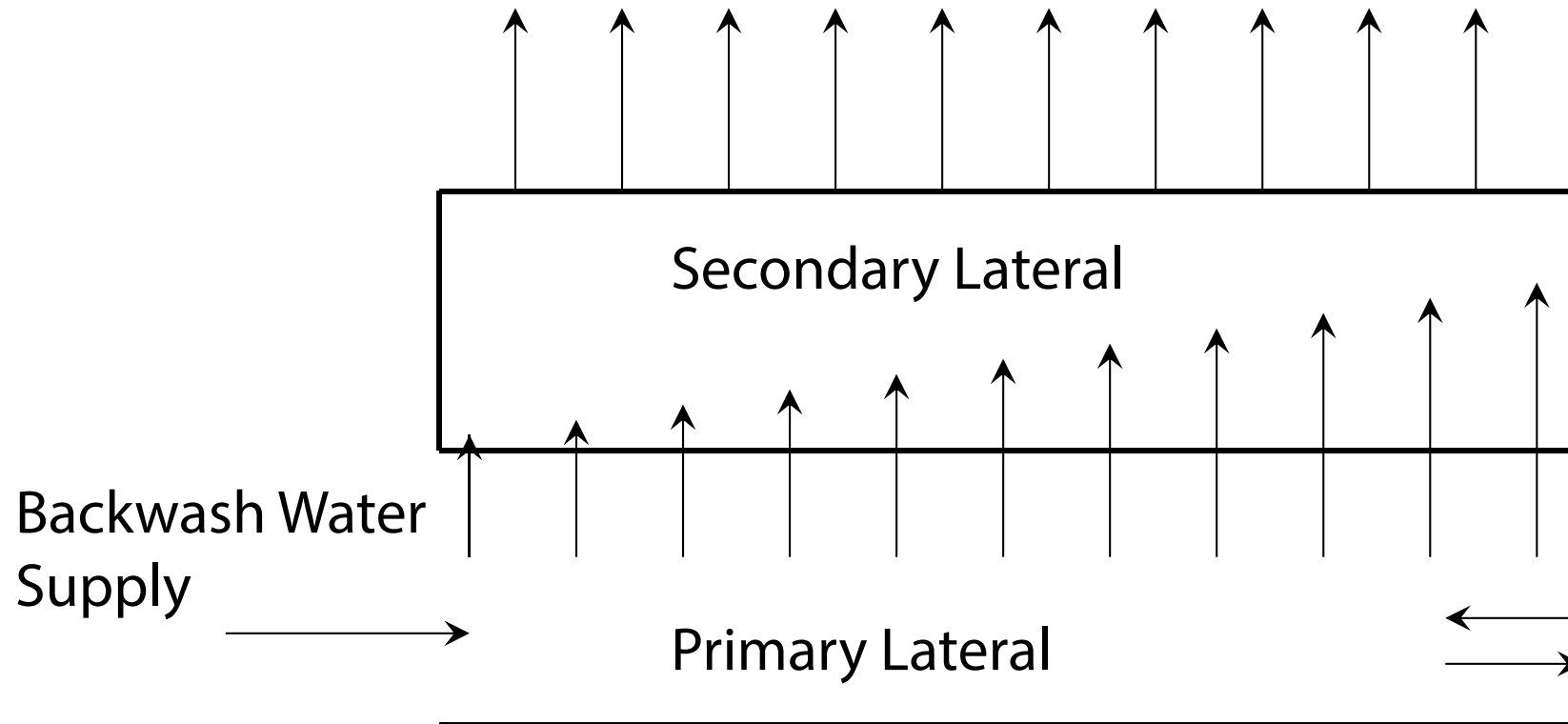

Unbalanced Flow in Primary Lateral creates an opposing flow that forms a compensating velocity pressure gradient, which puts the Secondary Lateral into a uniform hydraulic pressure condition

Typical Operating Parameters

Typical Backwash Sequence

- ④ Air & Water
 - Air Scour @ 2.5 – 4 scfm/sf, 1 min.
 - Air/Water @ 4 scfm/5 gpm, 3 min.
 - Water Purge @ 5 gpm/sf, 2 min.
 - Water Wash @ 17 gpm/sf, 5 min.
 - 110 gallon/sf water used
- ④ Water Only
 - High Wash @ 17 gpm/sf, 10 min.
 - 170 gallons/sf water used

Filtration Rates

- ④ ~10 gpm/sf (25 m³/m²-hr) maximum filtration rate
- ④ 2 – 6 gpm/sf (5 – 15 m³/m²-hr) typical design filtration rates

LP Block - GroutGrip[®]

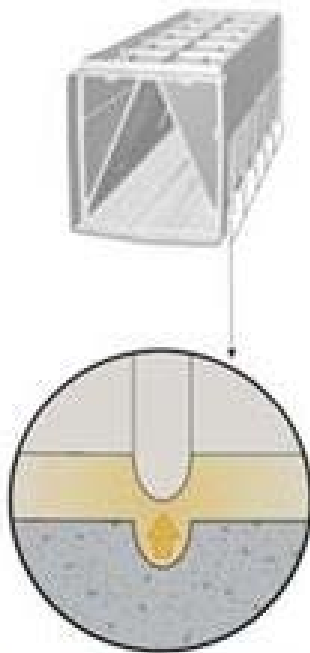

Conventional block with standard pullout strength

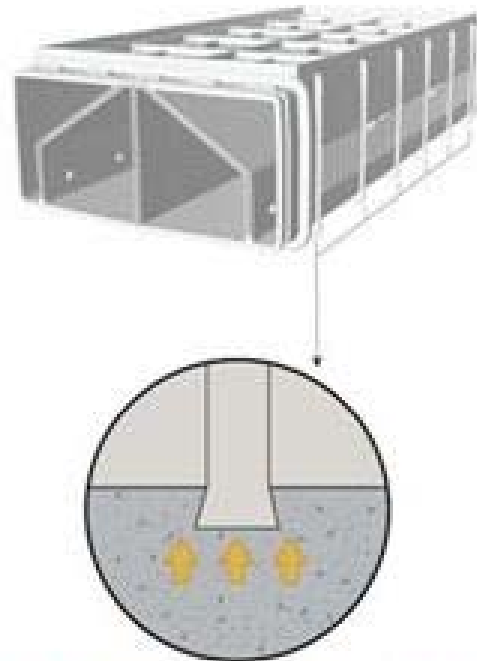

LP Block[™] featuring Grout Grip[™] has 3 times conventional block pullout strength

LP Block - Anchor-Rite[®]

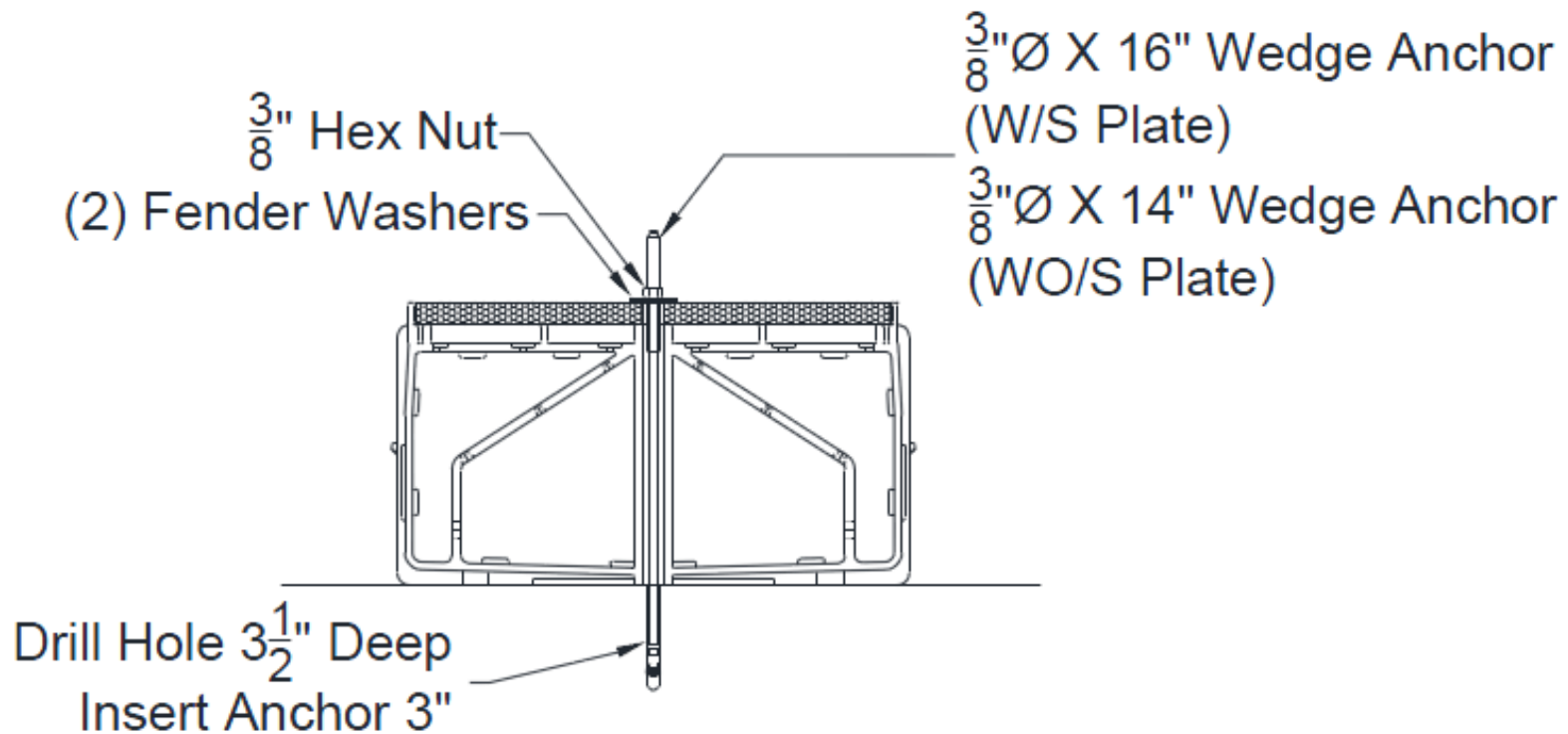

LP Block Views



GroutGrip



Anchor-Rite Opening



LP Block Flume Block Anchor-Rite Position

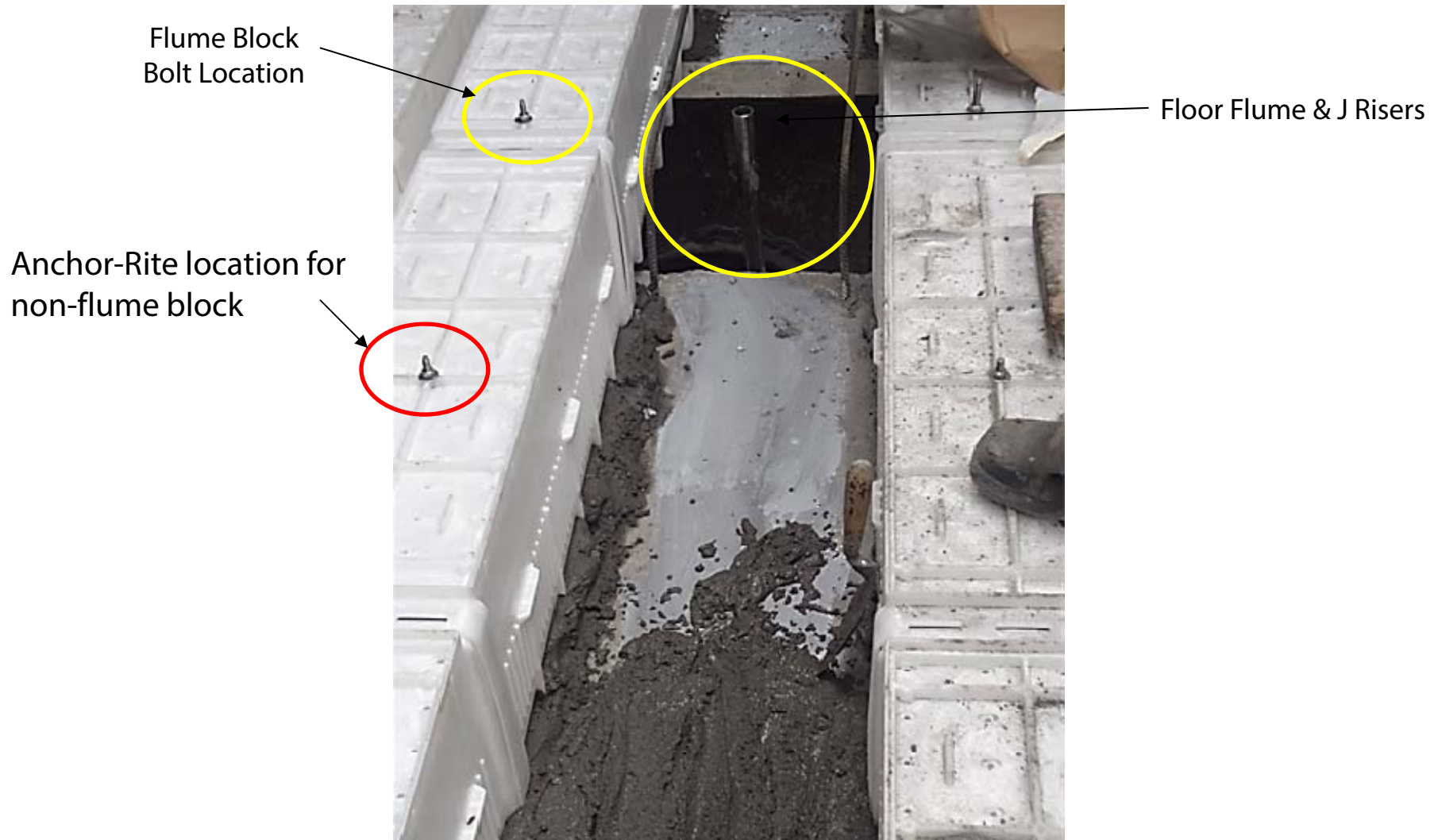

TETRA LP Block - Features & Benefits

Annual Underdrain Replacement & Repair Cost due to Underdrain Lifting Failures (DPL Plastic Underdrain only)

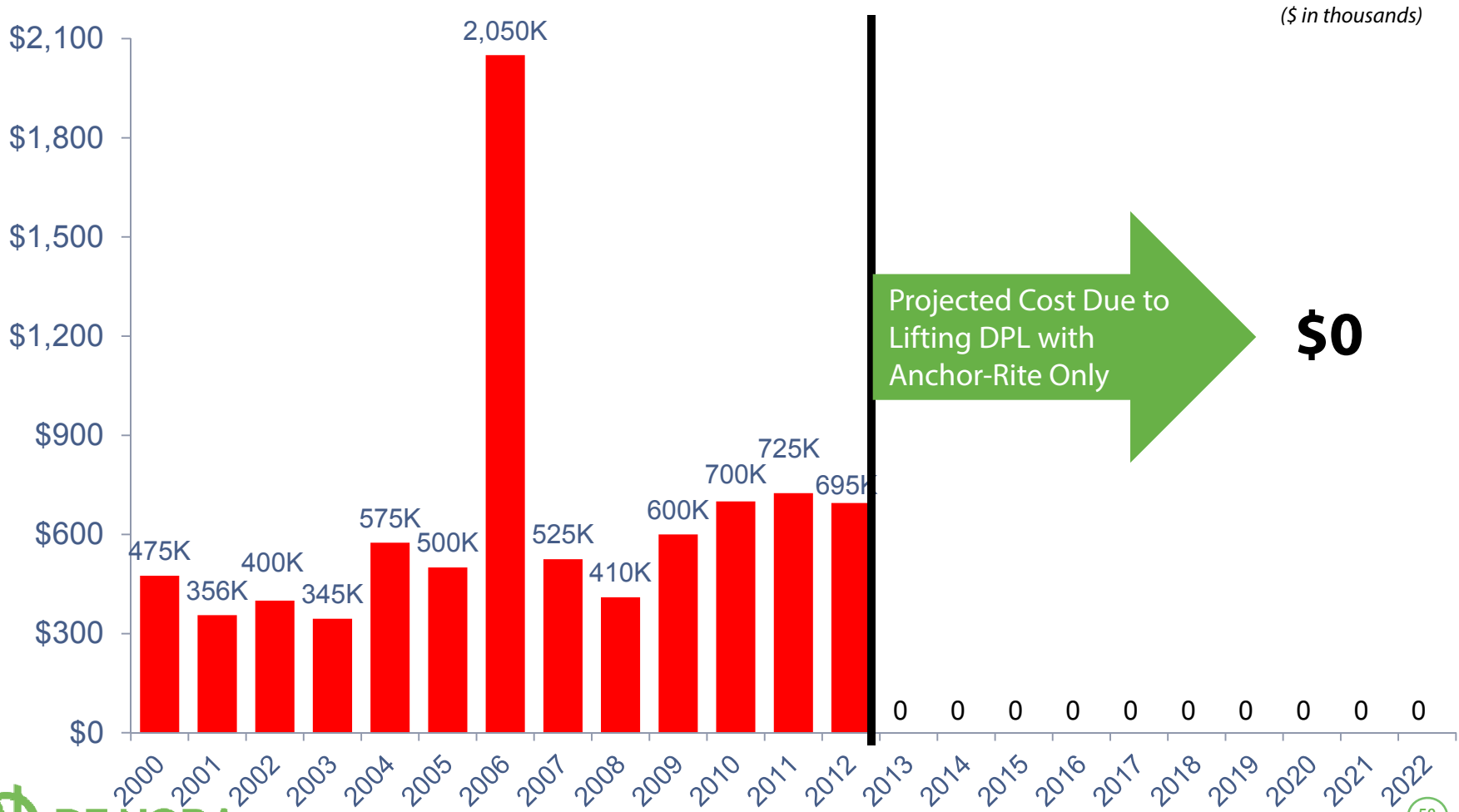

LP Block – FlumeFlow™

Works in conjunction with LP underdrain

Eliminates expensive fabricated air headers

FlumeFlow™ interface plate contains a baffle that creates a water chamber and an air chamber. Provides balanced pressure between air and water to ensure proper distribution

Air is pumped into top of an enclosed chamber, which displaces water through slots until top of Air L-pipe is exposed to air. After purging water, air passes through L-pipes to each lateral via the FlumeFlow interface plate

Installed in desalination plants in S. America and EMEA

LP Block - FlumeFlow

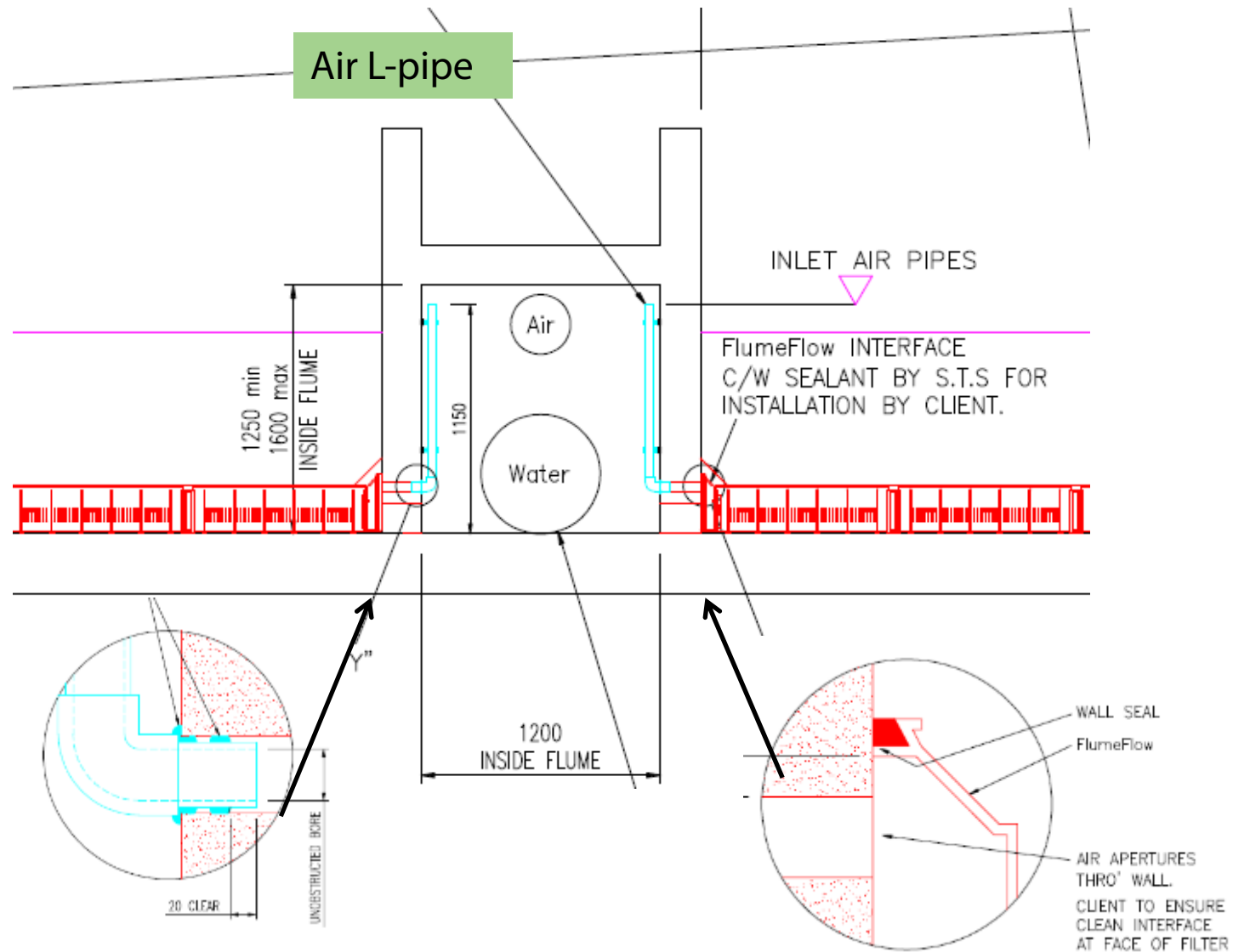

LP Block - FlumeFlow

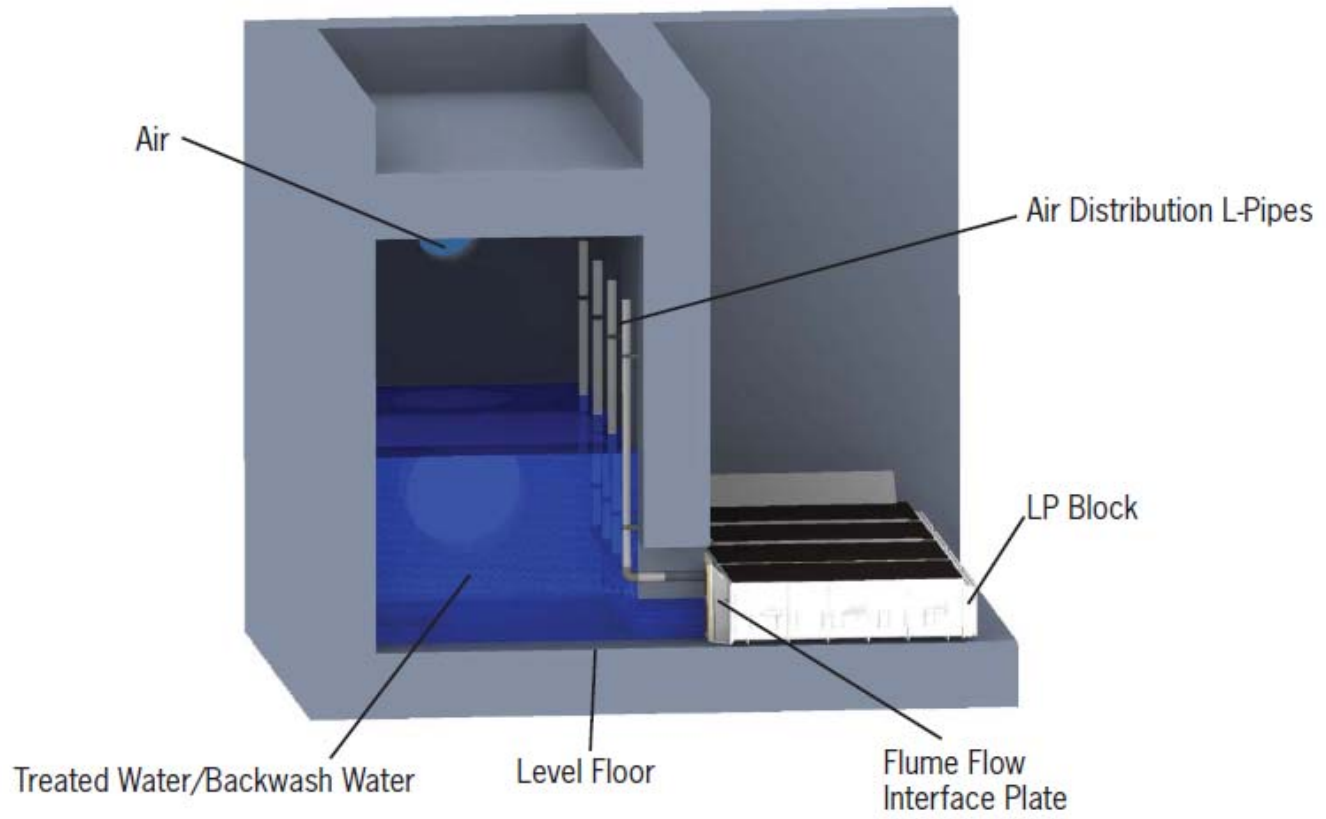

LP Block - Media Retention Plates

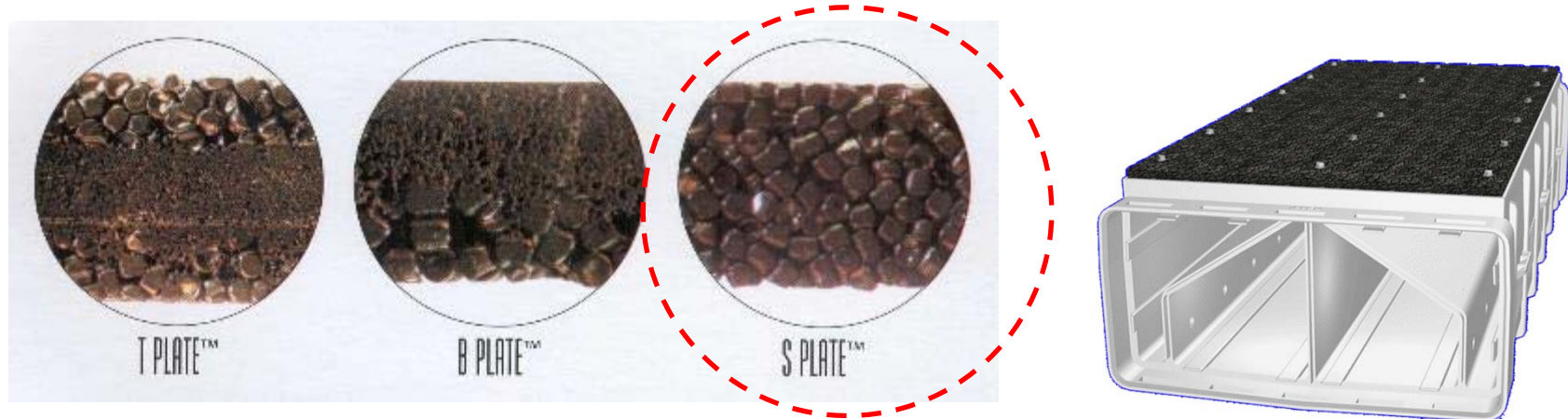

1" plate replaces 12" gravel

Provide uniform distribution at a head loss similar to 12" gravel

Made of porous 500 μm & 300 μm HDPE

Compatible with water treatment chemicals

Factory sealed and mounted with 316 SS Screws

LP Block - Media Retention Plates

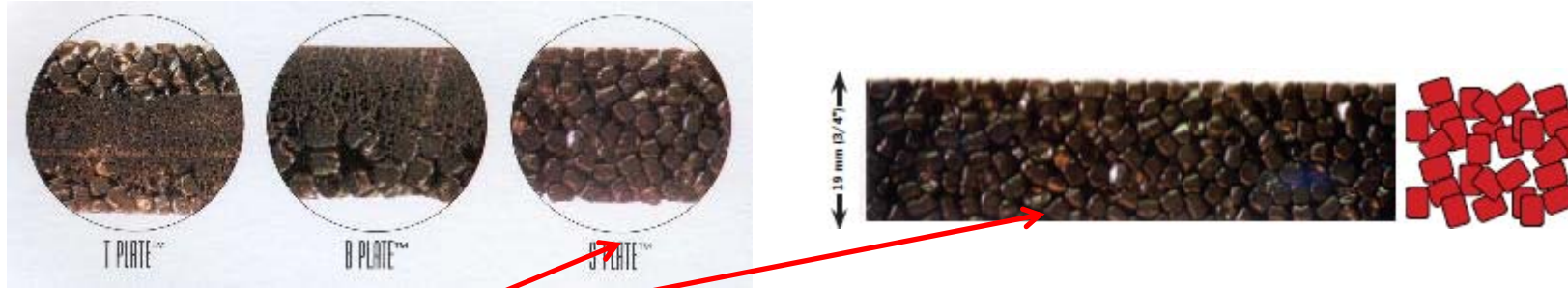

S Plate™

- ④ Single porous layer with an effective pore size of 500 micron.
- ④ Designed to retain media ES 0.45 -0.55 mm or larger
- ④ Material HPDE (UV resistant)
- ④ Construction Single layer of beads to give 500 micron +/- 25% void size
- ④ Dimensions 19mm thick x 403mm width x 858mm length.
- ④ Weight 4.2kg each (approximately)
- ④ Bulk Density 0.6kg/l to 0.65 kg/l
- ④ Pore Volume 40% to 55%

TETRA LP Block References

Largest desalination plants in Europe and the Middle East use LP Blocks for pre-treatment

Installations of new Anchor-Rite solution in Asia Pacific, EMEA and Americas regions with further orders under installation

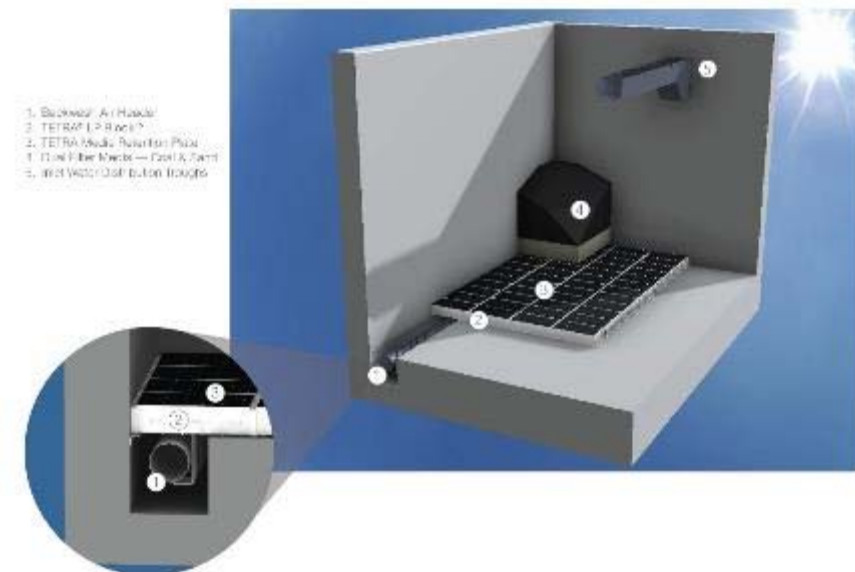

Disinfection Solutions

DISINFECTION SOLUTIONS
De Nora Water Technologies

Disinfection Solutions



ClorTec®
Brine Electrochlorination



EST™
Scrubbers



OMNIPURE™
Marine Sewage Treatment



SEACLOR®/SANILEC®
Seawater Electrochlorination



BALPURE®
Ballast Water Management

Capital Controls[®] - Gas Feed Disinfection

De Nora Water Technologies

Gas Feed Systems & Related Products

The Capital Controls® line of gas feed disinfection equipment includes chlorination, dechlorination/sulfonation, ammoniation & recarbonation equipment.

- Ⓢ Vacuum Gas Feeders (Manual & Automatic) up to 200 kg/h (10,000 ppd)
- Ⓢ Pressure Gas Feeders (Manual/Automatic) up to 20 kg/h (1,000 ppd)
- Ⓢ Automatic Gas Control Valves
- Ⓢ Vaporizers up to 227 kg/h (12,000 ppd)
- Ⓢ Custom Engineered Systems
- Ⓢ Chemical Induction Units



Gas Feed Disinfection – The DNWT Advantage

1. Capital Controls history – 50 years
2. Global installations & expertise
3. Reliable & robust solutions
4. A trusted brand
5. End-to-end solutions
6. Global support channels
7. All vacuum systems



Capital Controls Invented The All Vacuum System

Eliminates dangerous chlorine pressure lines & chlorine solution lines

Competition has copied this design because it is the safest method to feed chlorine gas

Capital Controls has 22 different mounting yokes, we can direct mount a chlorinator on any chlorine cylinder in the world, and many chlorine ton containers as well.



ADVANCE All Vacuum System

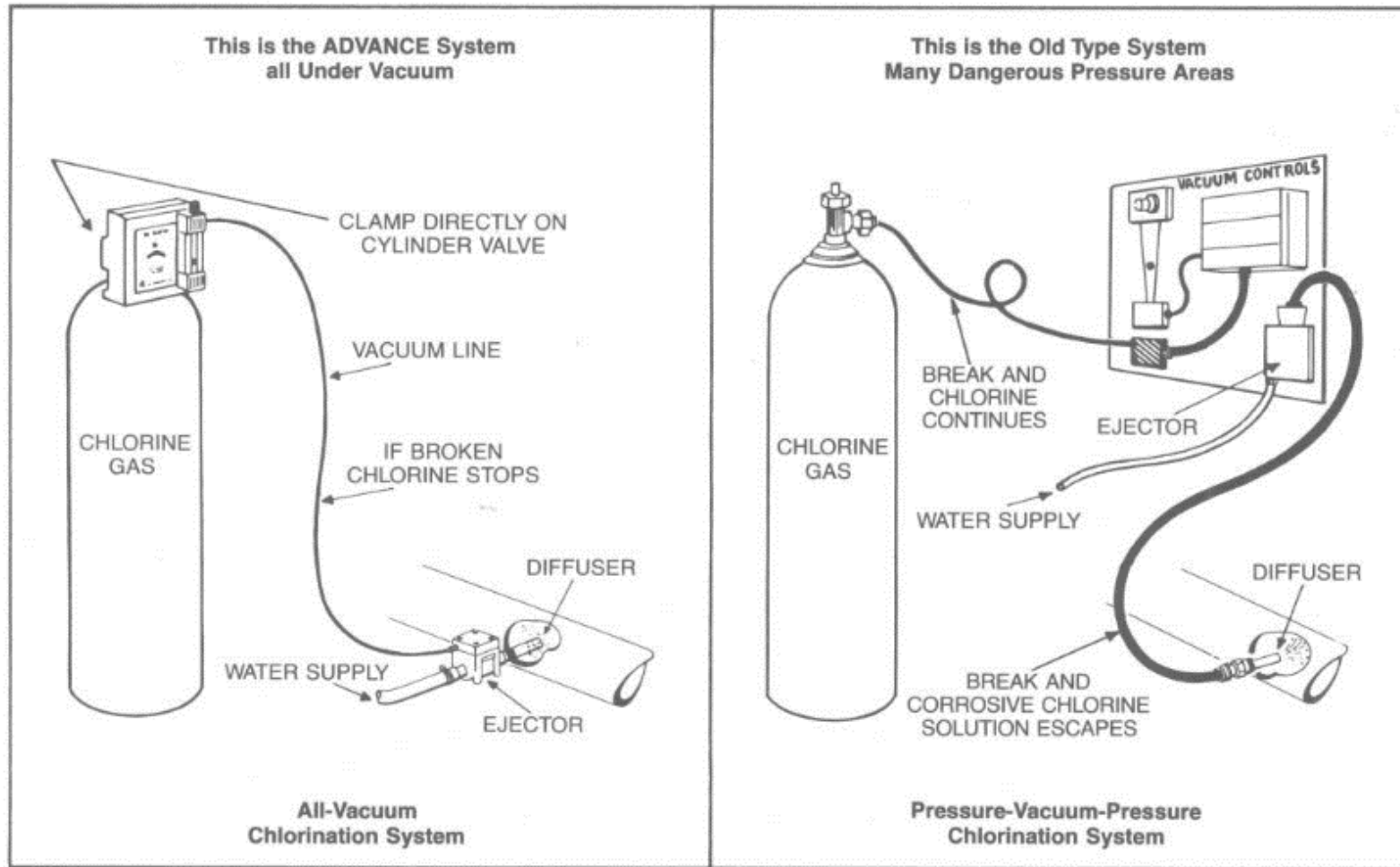

Capital Controls Has Been A Member Of The Chlorine Institute Since 1972

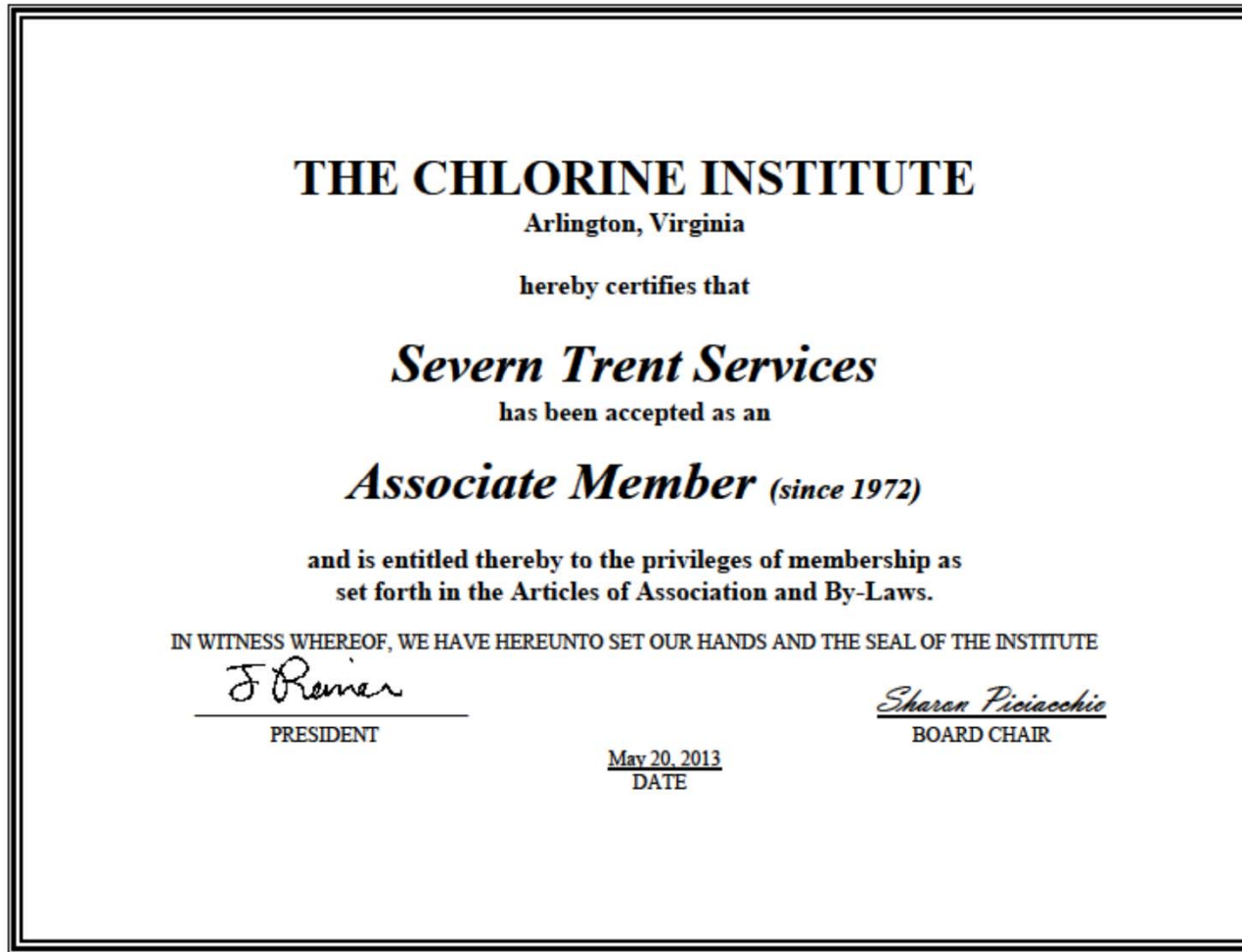

Manual Gas Feeders To 500 PPD

Series NXT3000/200 (vacuum)

- Ⓢ Chlorine - 500 PPD (10 kg/h)
- Ⓢ Sulfur Dioxide - 475 PPD (9.5 kg/h)
- Ⓢ Ammonia - 250 PPD (5 kg/h)
- Ⓢ Carbon Dioxide - 390 PPD (7.8 kg/h)

Series 480 (vacuum)

- Ⓢ Up to 100 PPD (2 kg/h)
- Ⓢ Chlorine

Series 600 (pressure)

- Ⓢ Up to 100 PPD (2 kg/h) for Chlorine
- Ⓢ Up to 250 PPD (5 kg/h) for Ammonia



Vacuum Regulator



Ultimate convenience: With or Without
Meter Assembly

Cylinder Or Ton Mounting



Cylinder



Ton

Meter Assembly

Solid Silver
Rate Valve

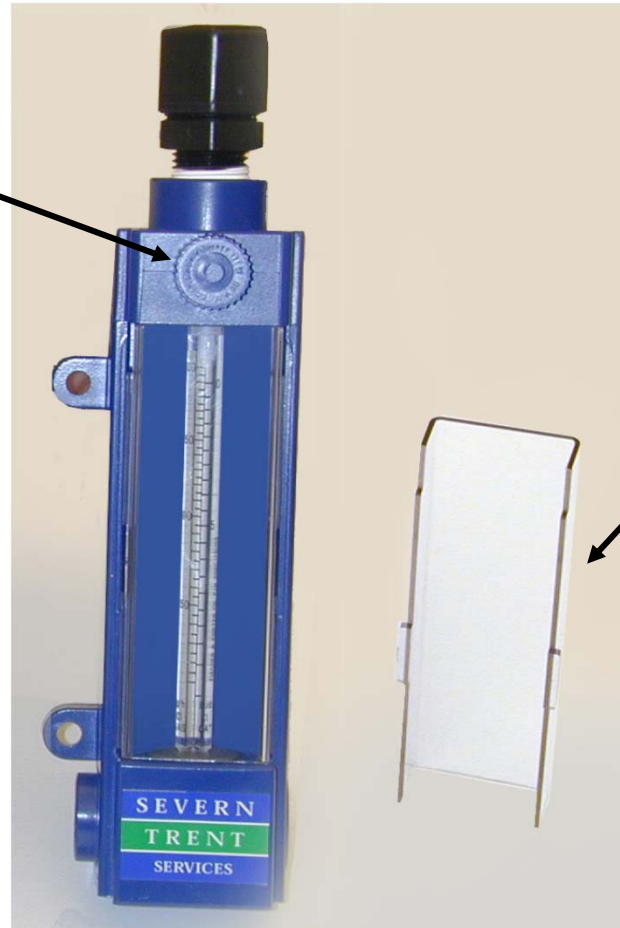

Removable
flowmeter
shield

Visual Indicating Lever



Easy to see vacuum regulator operating mode

Wall/Ton Manifold With Heater



Pressure Gauge



Optional manifold
mounted Pressure
Gauge

Vacuum Switches



Optional - Wall Mounted Nema 4X Vacuum Switch Box can be used to signal High and/or Low vacuum conditions

Ej17c Ejector Check-valve

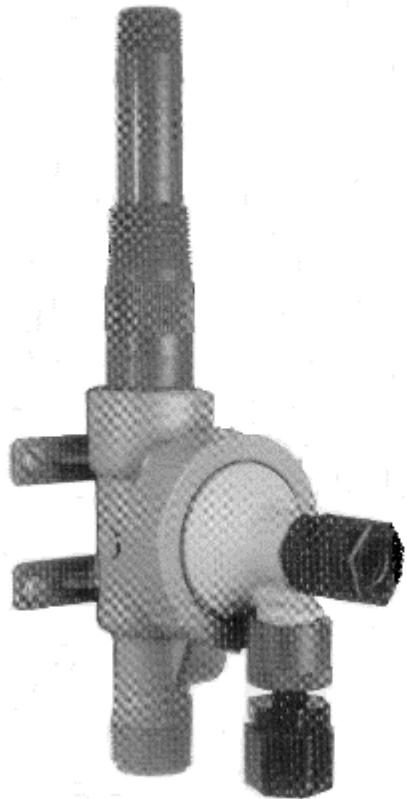

Dual check valves plus drain valve to prevent water backing up into the chlorinator

Optional anti-siphon valve

70CV3000 Smart Valve



Automatic control valve with integral controller

3 input capability

Sonic velocity

Capacities to 3000 ppd
(60 kg/hr)

WP70CV3 Wall Panel



Capacities to 3000
ppd (60 KG/h)

Optional High &
Low Vacuum
Switches

Gas flowmeter and
vacuum gauge

Sonic operation

Cabinet Mounted Gas Feeders



FX4000



FX44/5500



FX48/4900



WX4100

Capacities from 10 PPD to
10,000 PPD (200 KG/h)

Cl₂, SO₂, NH₃ & CO₂

Cabinet bezel easily
removable for service

Automatic or manual control

All control components in
cabinet except remote VR and
ejector

Cabinet Mounted Gas Feeders



Series FX4000

Manual by-pass

Vacuum gauge

Capacities: 10 – 10,000 PPD

D.P. Regulated, i.e. non-sonic

Cabinet mounted 1450 Controller available

Cabinet Mounted Gas Feeders



Series 4800/4900

Space-saving design

Capacities: 10 – 8000 PPD

Manual bypass

Remote Model 1450 Controller

Vacuum gauge

Wall Mounted Gas Feeders



WX4100 Series

Capacities: 10 – 8000 PPD

Manual bypass

Cabinet mounted 1450 for
automatic control

Vacuum gauge

Front access, easy to remove cover

Cabinet Mounted Gas Feeders



Series FX4400 (Chlortrol)

Vacuum gauge

Sonic up to 3000 PPD, advantage over W&T

Capacities: 10 – 3000 PPD

Auto/Manual & +/- switches

71RC5000 Controller available

Flow pacing – requires only Chloromatic Valve

Ejector: Ball check and drain valve

Cabinet Mounted Gas Feeders



Series FX5500

D.P. Regulated (non-sonic)

Capacities: 1000 – 10,000 PPD

Auto/Manual & +/- switches

71RC5000 Controller available in the cabinet

Vacuum gauge

Flow pacing – requires only Chloromatic Valve

FX4000 – Vacuum Regulators

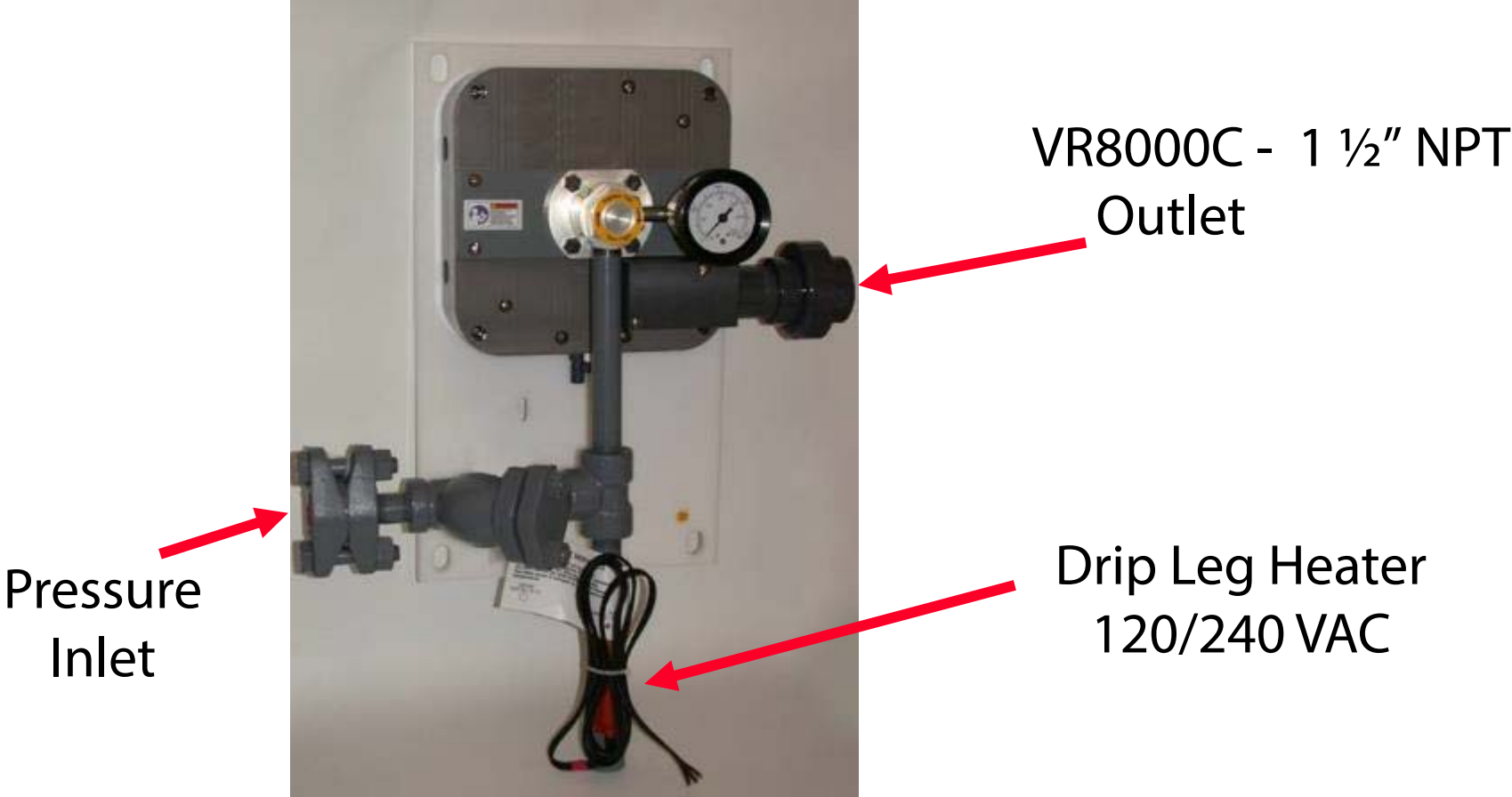

FX5500 Series – Vac Regulator



2" NPT Vacuum Outlet

Optional Low Temperature
Switch Port

Pressure Gauge

1" NPT Pressure
inlet

Manifold
Heater

High Capacity Ejectors



Chlortrol ejectors

- Ø 2 and 3"
- Ø 3,000 to 10,000 ppd
- Ø Ball check valve and drain valve



Advance Ejectors

- Ø 2-3 and 4"
- Ø Fixed and variable orifice designs
- Ø 2,000 to 10,000 PPD

Vaporizers



Vaporizers

Electrically heated vaporizer 71v3000

- ④ Safest design in the industry. 1/2" pressure vessel wall thickness exceeds ASME boiler and pressure vessel code by more than 50%
- ④ ASME "L" stamp (welding meets lethal gas requirements)
- ④ NEMA 4X controls (temperature controller w/ integral alarm settings, water level controls)
- ④ Efficient heat transfer design. No circulation pumps are required. Superheat baffle design ensures full capacity vaporization
- ④ Large 8" diameter chamber maximizes heat transfer area and minimizes cleaning requirements

Vaporizers

Electrically heated vaporizer 71v3000 (cont.)

- ④ MAXIMUM CAPACITIES:
 - Chlorine - 12,000 Lbs/24 hrs (227 kg/hr)
 - Sulfur Dioxide - 7,500 Lbs/24 hrs (140 kg/hr)
 - Ammonia - 2,100 Lbs/24 hrs (40 kg/hr)
- ④ Automatic solid state cathodic protection current regulation w/ indicator lights showing "ON" or "FAILED" conditions as standard
- ④ Closed cell foam insulation on water chamber
- ④ Integral or remote contactors/disconnects
- ④ Easy cabinet removal allowing full maintenance access

Vaporizer Chambers

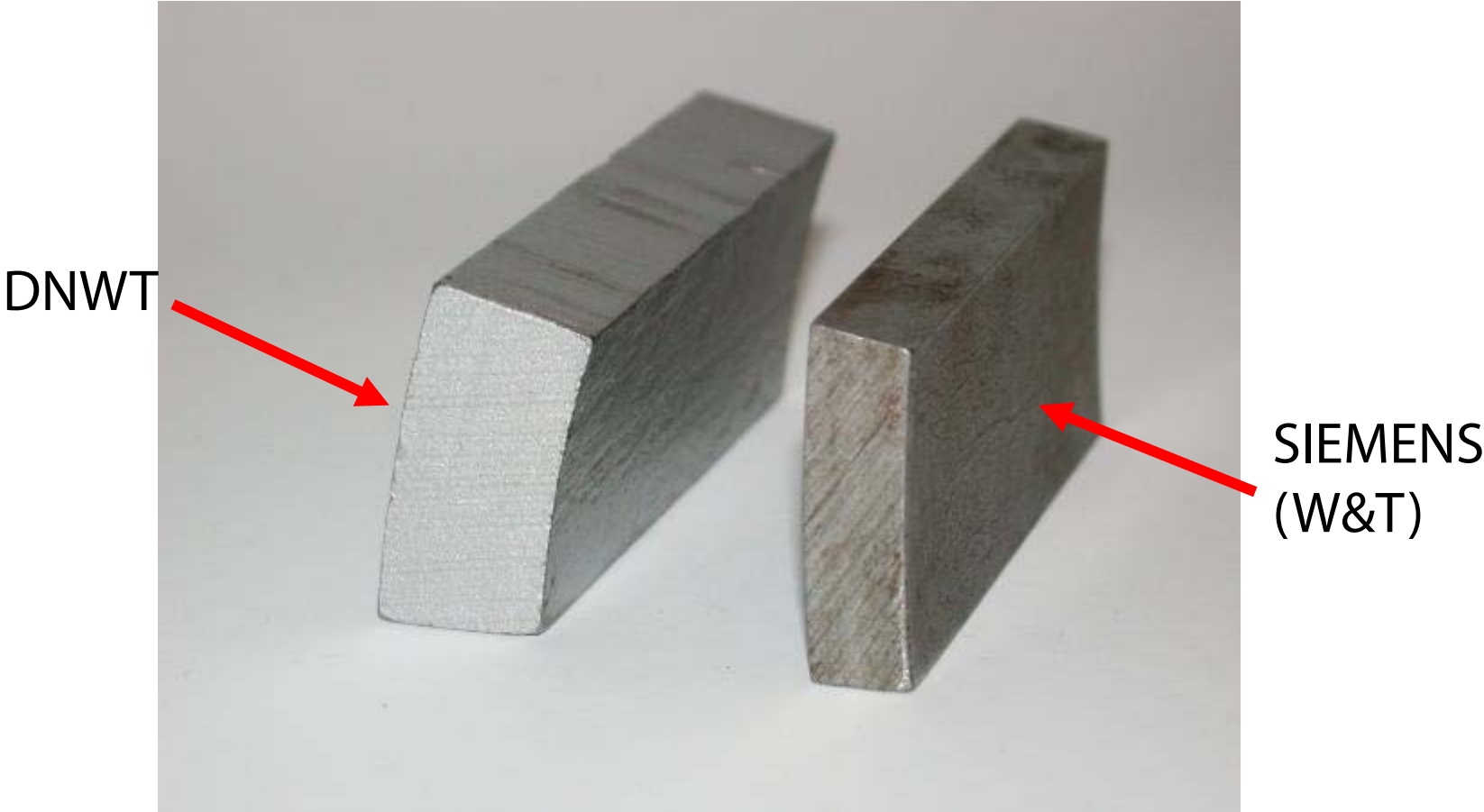

Which chamber would you rather have?

Why Capital Controls Chlorinators?

We understand our clients' needs having previously been part of a large water company

We invented the all vacuum system for safety and simplicity

We are the most copied brand in the world: Hydro, Ecometrics, Sureflow, Enchlor, Controlmatic

We were the first to attain ISO Certification

Safest liquid chlorine vaporizer available

We understand disinfection, we have OSHG, chlorine dioxide, UV, emergency gas scrubbers, we are not just a chlorinator company

Regional and local sales and service

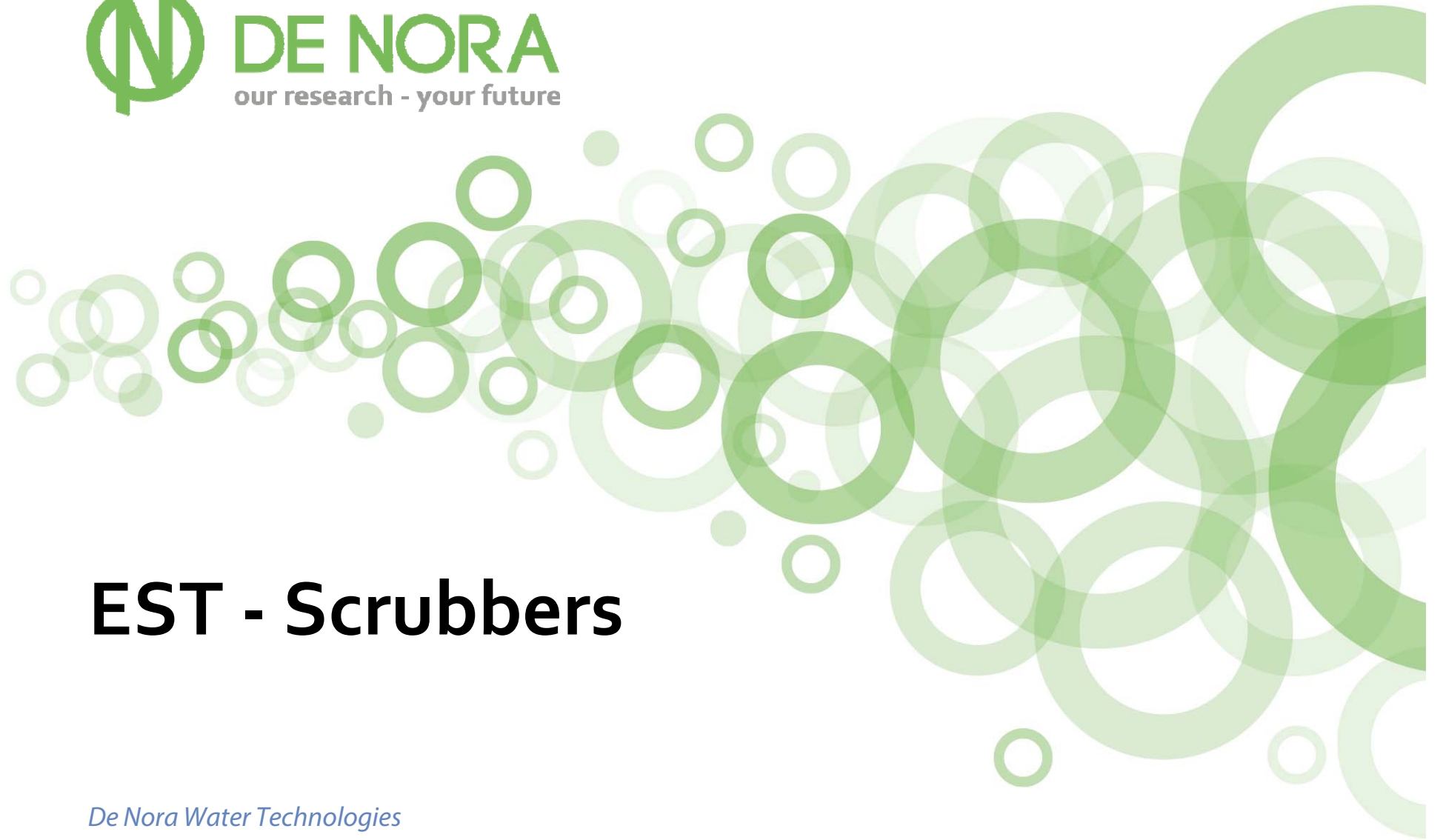

EST - Scrubbers

De Nora Water Technologies

EST Emergency Gas Scrubbers Ejector Venturi / Packed Tower

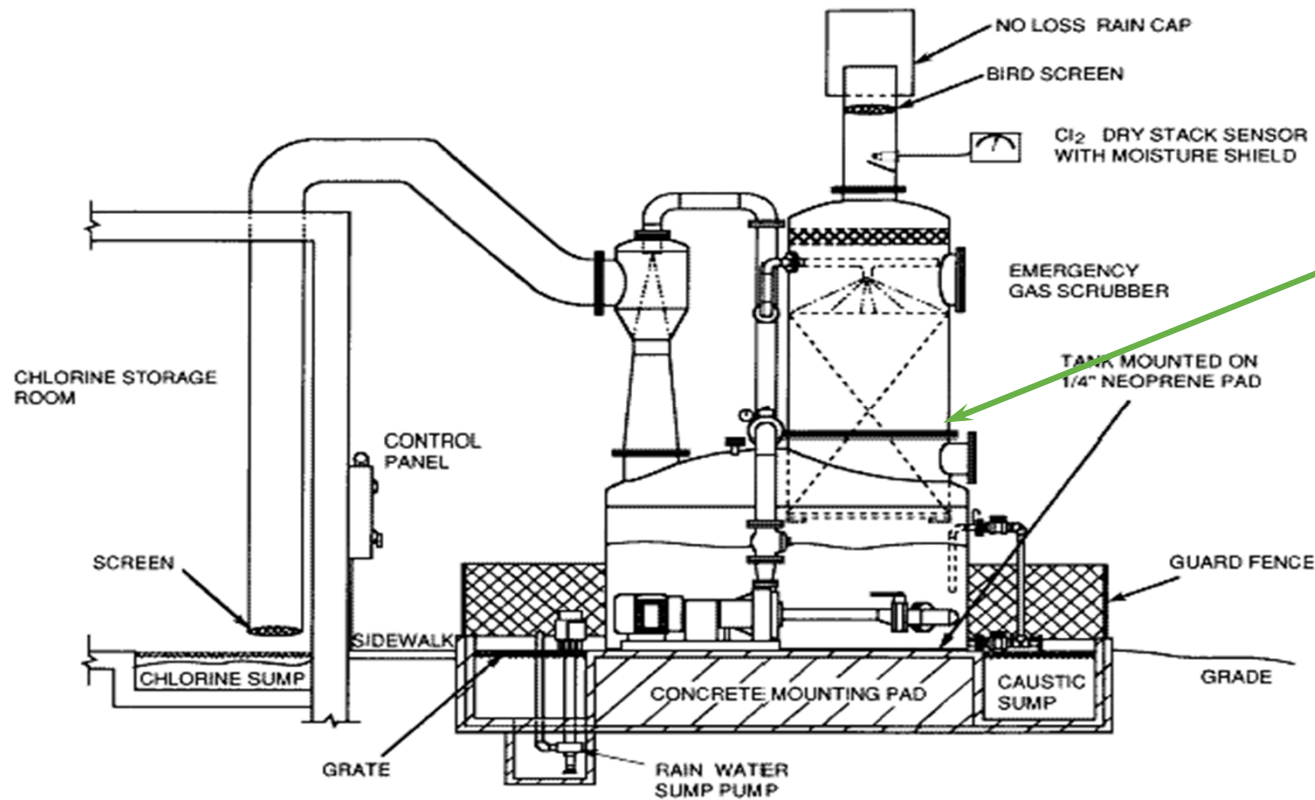

**High
Performance
Packing Media**

EST Low Profile Once Through MVP Gas Scrubber

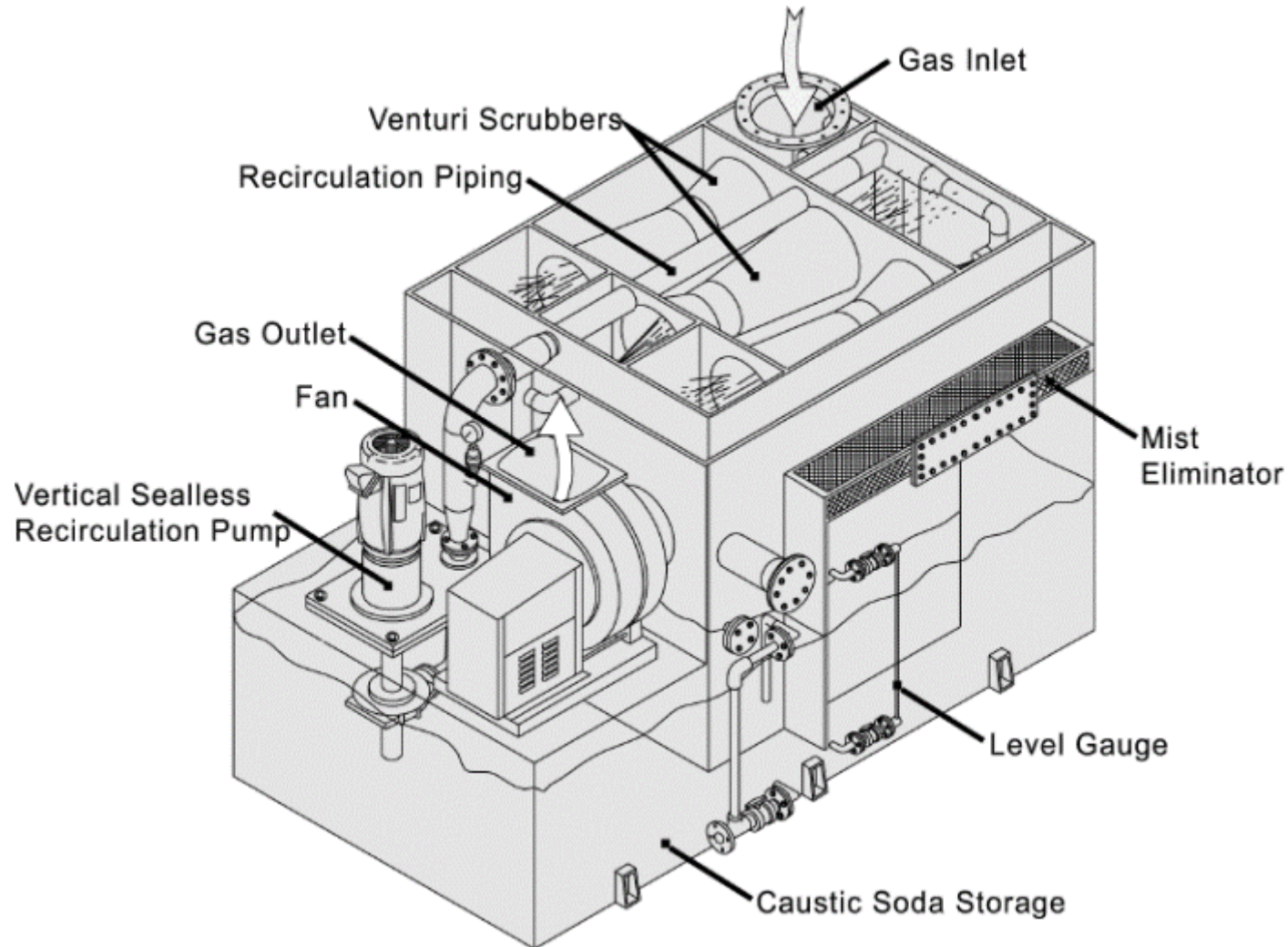

EST Type “DES” Dry Emergency Gas Scrubber

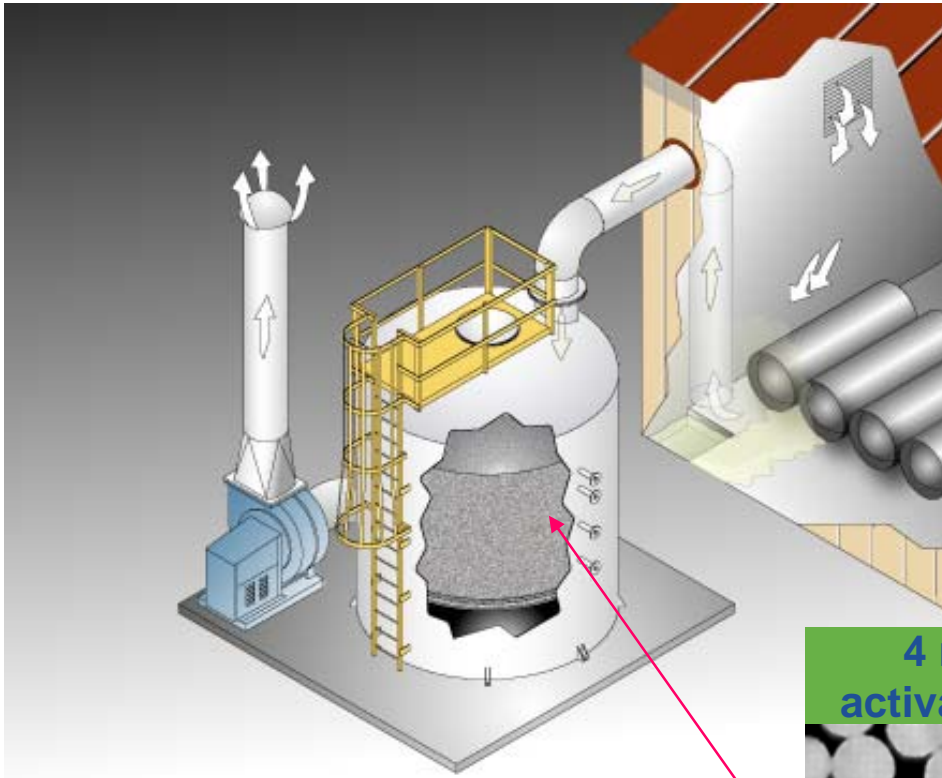

1. No chemical maintenance
2. Spent media is non-hazardous waste
3. One moving part - fan
4. No chemical recirculation pumps or piping
5. Chemical leak containment is not required
6. Can operate at sub-zero temperatures without heating

4 mm impregnated
activated alumina pellets

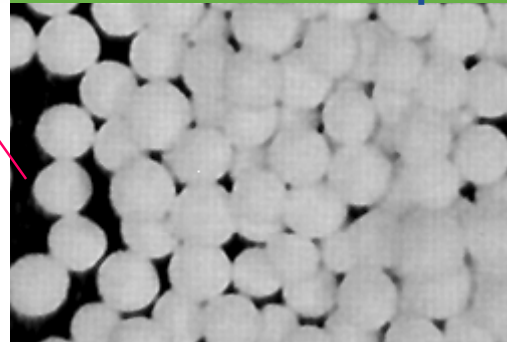

Chlorine Residual Analyzer Products

Capital Controls® offers the most complete line of chlorine residual analyzers on the market today

Products that use Amperometric Technology:

- ④ 1770 bufferless analog analyzer
- ④ Proven, reliable 1870E buffered analog analyzer
- ④ Microprocessor based CL500 buffered
- ④ Microprocessor based CL1000 buffered



MicroChem[®] 2 Series 4000



MicroDPD[®] Colorimetric DPD Analyzer

- Will measure Free or Total Chlorine
- 0-10mg/L – wide range for diversified applications
- 4-20mA (600 ohm) – can use to retransmit measurement and control chlorine feed
- Low operating costs – change reagents monthly and tubing either quarterly or yearly
- Two User Selectable Alarms – used for concentration or fault
- Competitively priced – improved features at low price
- Arrives completely calibrated – fast and easy startup



Capital Controls Gas Detectors



1610B: 1 Channel Analog



1620B: 8 Channel Analog



17CA4000: 1 Channel



17CA3000: 4 Channel Digital

Sg Dua WTP, Penang, Malaysia



Busselton WTP, Australia



Chengdu #6 WTP, China



Valmayor, Spain



East Bank & West Bank WTPs, New Orleans, La



Balara WTP, Quezon City, Philippines



Singapore PUB



Emergency Gas Scrubbers

Dry Scrubber, Busselton,
Australia



Wet packed tower scrubber,
Cau Do, Vietnam



- QUESTIONS

For Product Inquiries, Please Contact Us

Pall Roces Corporation | Water Quality Solutions Provider

G/F Crystal Mansion Building

#14 South A-A Street

Corner Don A.Roces Avenue

Quezon City, Metro Manila, Philippines

+63 2 3739359

+63 2 4144969 to 70

<http://www.pallrocescorp.com>